



**bosal**

© Bosal Plant 42

Part number: 038424

Type number: 038424

Instrukcja montażu  
Порядок установки

## Volkswagen UP (Hatchback)

🕒 12/2011 →

Instruction de montage  
Montagehandleiding

## Seat Mii

🕒 12/2011 →

Montagevejledning  
Instrucciones de montaje

## Skoda Citigo

🕒 12/2011 →

Monteringshandleiding  
Návod k montáži

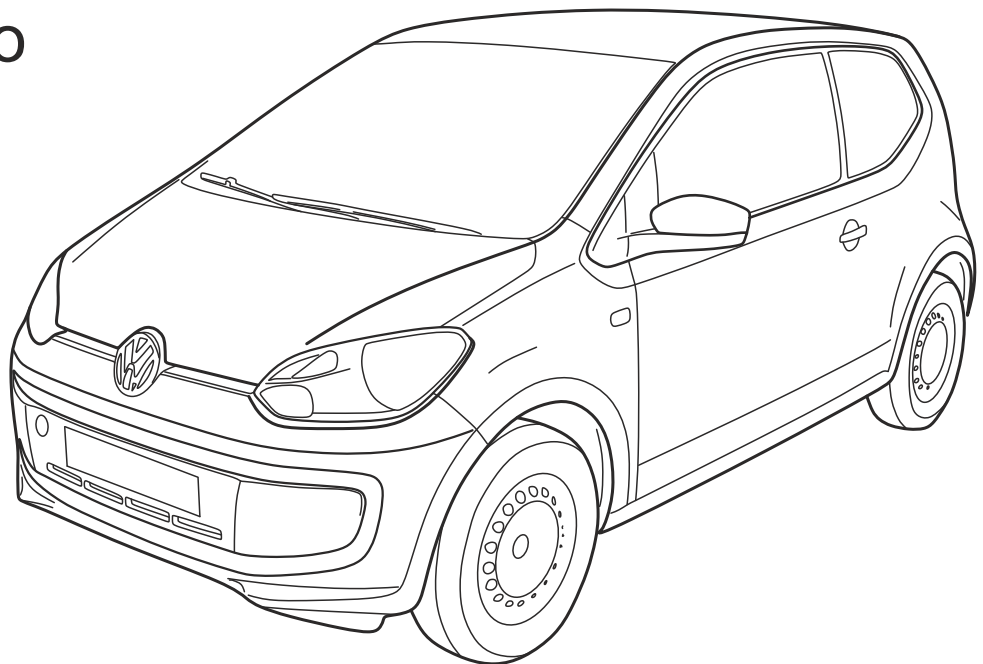

Istruzioni di montaggio  
Monteringsveiledning

Montageanleitung  
Asemunusohje

- Ⓝ *Alleen te gebruiken als fietsendrager. Het is niet toegestaan om deze constructie voor andere doeleinden te gebruiken.*
- ⓓ *Nur als Fahrradträger zu benutzen. Es ist nicht erlaubt diese Konstruktion für andere Zwecke zu verwenden.*
- ⓖ *Use only as bicycle carrier. It is not allowed to use this construction for any other purposes.*
- ⓕ *Utiliser seulement comme support de bicyclette. Il n'est pas permis d'utiliser cette construction à d'autres fins.*

Date: 30-07-2013

Version: 04





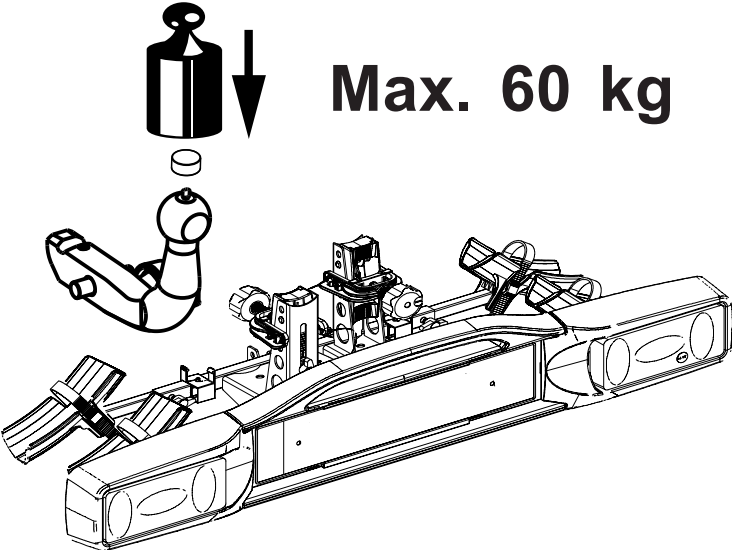

ECE R26  
homologation

# E7 26R-011202



**Max. 60 kg**

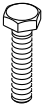



|  |  |        |  |        |
|--|---|--------|---|--------|
|  | 8.8   | 10.9   | 8.8   | 10.9   |
| M6   | 9,5 Nm  | 14 Nm  |   |        |
| M8   | 23 Nm   | 34 Nm  |   |        |
| M10  | 46 Nm   | 68 Nm  |   |        |
| M12  | 79 Nm   | 117 Nm |   |        |
| M12x100/110  |   |        |   | 100 Nm |
| M14  | 125 Nm  | 185 Nm |   |        |
| M16  | 195 Nm  | 280 Nm |   |        |
| M10x1,25   | 49 Nm   | 72 Nm  |   |        |
| M12x1,25   | 87 Nm   | 125 Nm |   |        |
| M12x1,5  | 83 Nm   | 122 Nm |   |        |

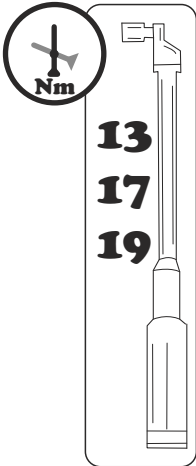

**1 h**

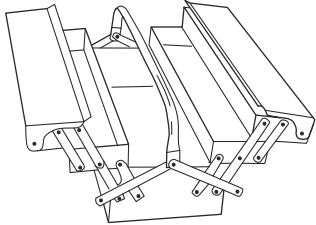
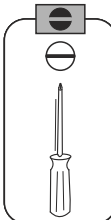

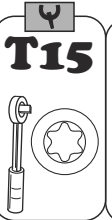
**13  
17  
19**

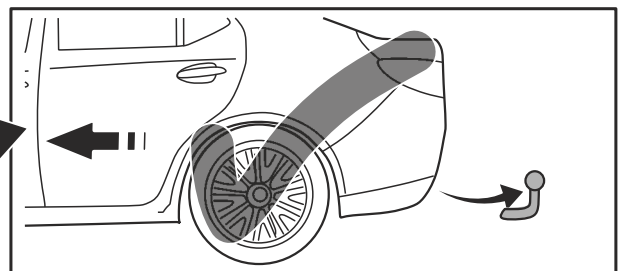
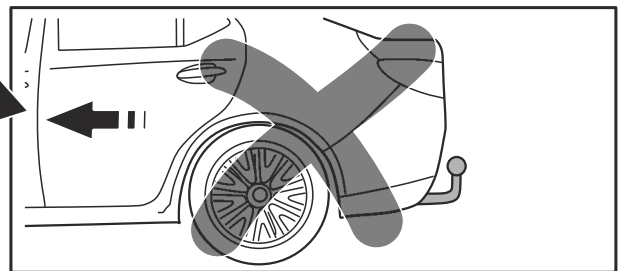
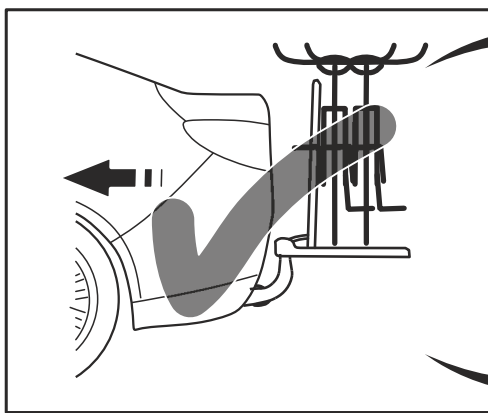
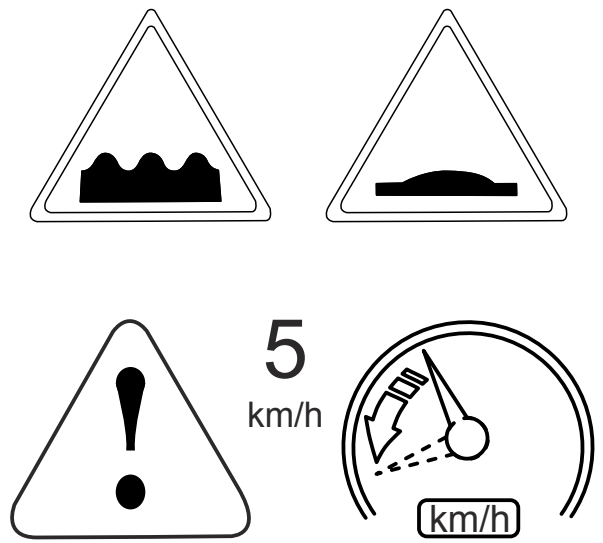
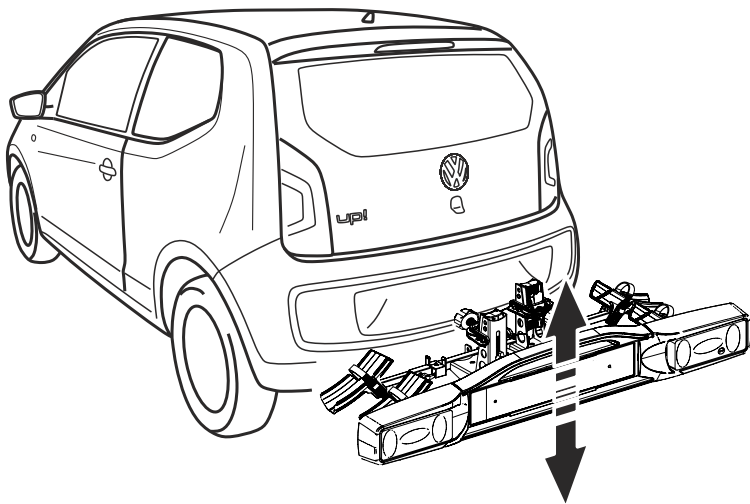
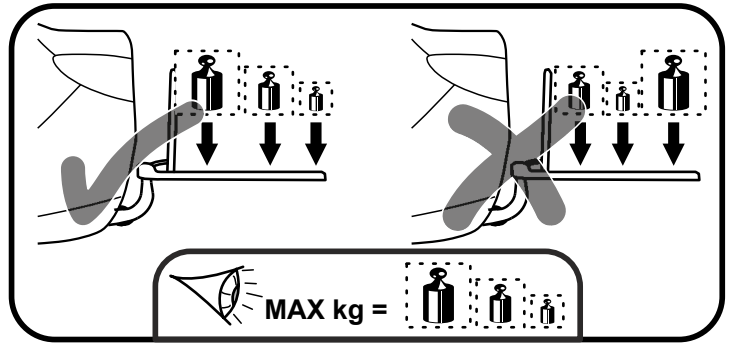
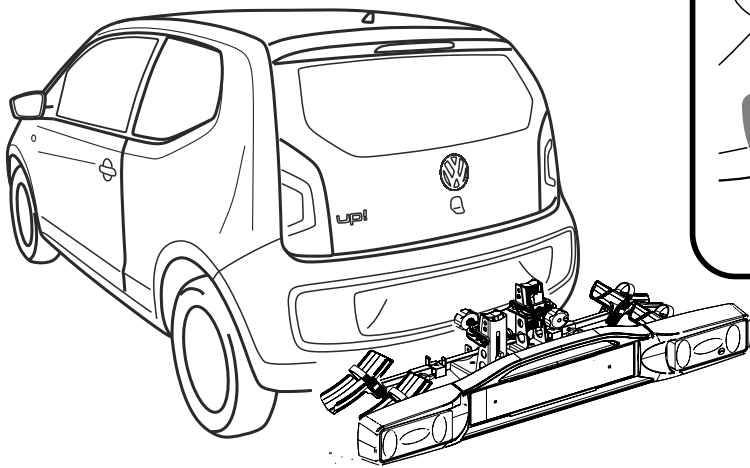

|    |   |    |
|----|---|----|
| 1  |   | 1x |
| 2  |  | 1x |
| 3  |  | 1x |
| 13 |  | 1x |
| 14 |  | 1x |

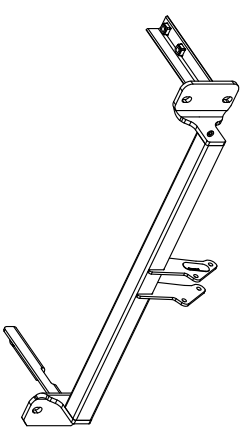
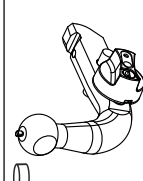
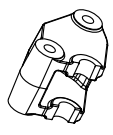
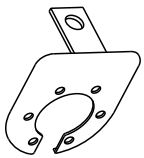
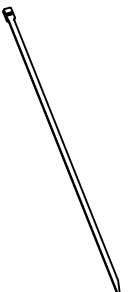
|  |                  |  |  |  |                                     |                                     |    |            |         |      |    |        |
|--|------------------|--|--|--|-------------------------------------|-------------------------------------|----|------------|---------|------|----|--------|
|  | <b>88.038424</b> |  |  |  | <input checked="" type="checkbox"/> | <input checked="" type="checkbox"/> |    |            |         |      |    |        |
|  |                  |  |  |  |                                     |                                     | 4  | M8x40      | DIN933  | 8.8  | 4x | 23 Nm  |
|  |                  |  |  |  |                                     |                                     | 5  | M10x100    | DIN931  | 8.8  | 2x | 46 Nm  |
|  |                  |  |  |  |                                     |                                     | 6  | M12x40     | DIN933  | 10.9 | 3x | 117 Nm |
|  |                  |  |  |  |                                     |                                     | 7  | M10        | DIN934  | 8.8  | 2x | 46 Nm  |
|  |                  |  |  |  |                                     |                                     | 8  | Ø22x8,5x3  |         |      | 4x |        |
|  |                  |  |  |  |                                     |                                     | 9  | Ø32x12,5x4 |         |      | 3x |        |
|  |                  |  |  |  |                                     |                                     | 10 | M8         | DIN128A |      | 4x |        |
|  |                  |  |  |  |                                     |                                     | 11 | M10        | DIN128A |      | 2x |        |
|  |                  |  |  |  |                                     |                                     | 12 | M12        | DIN128A |      | 3x |        |

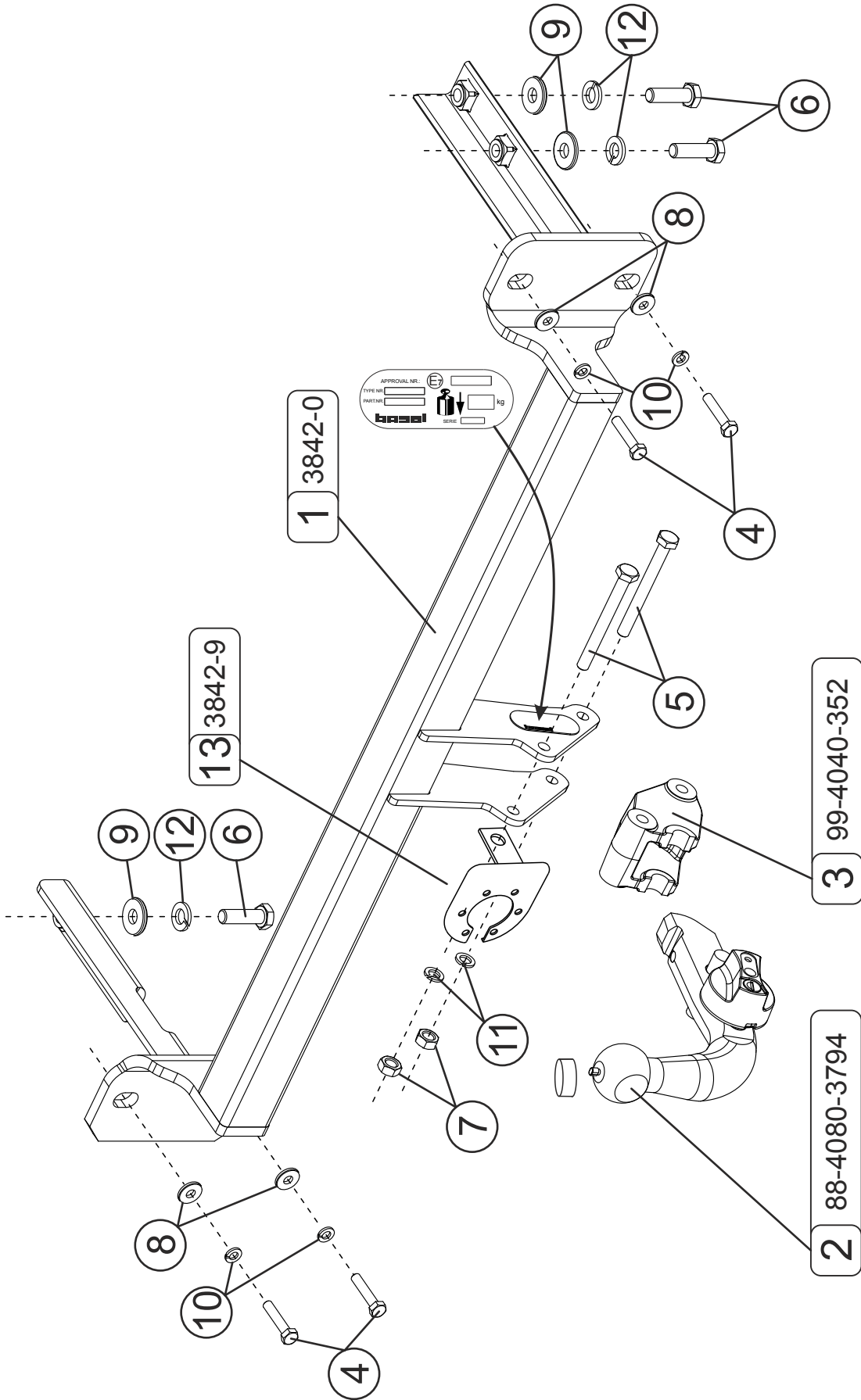

**NL** Nationale richtlijnen betreffende de montagegoedkeuring moeten in acht worden genomen.

Deze montage- en gebruikshandleiding dient aan de voertuigdocumenten te worden toegevoegd.

Bosal kan niet aansprakelijk worden gesteld voor enig gebrek in het produkt zoals veroorzaakt door de schuld of door welk onoordeelkundig gebruik ook van de gebruiker of een persoon voor wie hij aansprakelijk is (art. 185, lid 2 N.B.W.).

Al onze producten worden gecontroleerd op compleetheid middels een weegcontrole systeem. Reclamaties met betrekking tot ontbrekende delen kunnen alleen geaccepteerd worden indien deze gewichtscontrole sticker kan worden getoond.

Het is noodzakelijk om na ca. 1000 km gebruik de boutverbindingen na te trekken (volgens gegeven aanhaalmomenten).

**D** Nationale Richtlinien über die Anbauabnahmen sind zu beachten.

Diese Montage- und Betriebsanleitung ist den Kfz.-Papieren beizufügen.

Für einen Mangel am Produkt, der durch den Fahrzeughalter oder eine andere Person aufgrund unsachgemäßer Benutzung verursacht wurde, übernimmt Bosal keine Haftung. (art. 185 lid 2 N.B.W.)

Bei der Auslieferung wird jedes unserer Produkte mit einem Gewichtskontrollsystem überprüft. Im Falle fehlender Teile können wir der Bitte nach Nachlieferung nur entsprechen, wenn auch der Aufkleber, der die Gewichtskontrolle bestätigt, mit eingesandt wird.

Nach ca. 1000 km die Bolzenverbindungen, wie angegeben, nachziehen.

**GB** National guidelines concerning official approval of accessories must be observed.

These installation and operating instructions must be enclosed with the vehicle papers.

Bosal cannot be held responsible for any defects in the product caused by fault or by any injudicious use whatever of the user or a person he is liable for. (sect. 185, art. 2 N.B.W.)

All our products are controlled upon dispatch with a weight control system. In the case of missing parts we can only accept a request of replacement with the weight control sticker.

After about 1000 km use, re-tighten the bolts and nuts to the specified torque.

**F** Les recommandations nationales concernant l'approbation officielle des accessoires doivent être prises en considération.

Ces instructions de montage et d'opération doivent être jointes aux documents du véhicule.

Bosal décline toute responsabilité concernant des défauts éventuels de cet attelage qui seraient causés par une mauvaise utilisation. Seul l'utilisateur est responsable.

Lors de la livraison, nous contrôlons tous nos produits par pesage de l'attelage. Dans le cas de pièce manquante, nous ne pouvons accepter une demande de supplément qu'avec l'étiquette certifiant le contrôle du poids.

Il est conseillé de vérifier le serrage de toute la boulonnerie après 1000 Km de traction.

- E** Hay que tener en cuenta las directivas nacionales referentes a la autorización oficial de los accesorios.

A las instrucciones de instalación y de funcionamiento hay que adjuntarlo a los papeles del vehículo.

Bosal no asume responsabilidad de ningún tipo por defectos en el producto causados por o debidos a un uso imprudente, tanto por parte del usuario como de cualquier persona bajo su responsabilidad (art. 185, párrafo 2 N.B.W. (Código Civil Holandés)).

En el transporte controlamos todos nuestros productos en un sistema de control de peso. En el caso de accesorios faltantes el pedido referente a su reemplazo sólo lo podemos aceptar conjunto con la presentación de la etiqueta adhesiva certificante del control de peso.

Cada 1000 km de uso es necesario comprobar las conexiones del perno (según los pares de apriete dados).

- DK** De officielle nationale retningslinier vedr. tilladelser skal overholdes.

Disse monterings- og driftsinstruktioner skal vedlægges køretøjets officielle dokumenter.

Bosal kan ikke gøres ansvarlig for mangler ved produktet, der er opstået som følge af skyld eller ukyndig anvendelse af brugeren eller en person, som han er ansvarlig for (§ 185, stk. 2 N.B.W. (hollandsk privatret)).

Ved levering kontrollerer vi alle vores produkter med vægtkontrolsystem. Rekvirering af manglende reservedele kan kun accepteres ved fremvisning af kontrolbilletten fra vægtkontrolsystemet.

Det er nødvendigt at efterspænde møtrikkerne efter ca. 1000 km.

- N** Det skal tas hensyn til nasjonale retningslinjer som gjelder offisiell godkjenning av tilbehør.

Disse monterings- og driftsveiledninger skal vedlegges kjøretøyets dokumentasjon.

Bosal kan ikke stilles ansvarlig for noen mangel ved produktet som kan forårsakes av skjodesløs eller ukyndig bruk. Ansvar er brukerens eget (paragraf 185, ledd 2 i den nederlandske sivilrettsligelovboken).

Ved transporten er alle våre produkter kontrollert ved hjelp av vektkontroll-systemet. I tilfelle manglende bestanddeler er erstatningen bare mulig ved framvisning av etiketten som attesterer vektkontrollen.

Det er nødvendig å etterstramme alle bolter etter ca. 1000 km (i henhold til de oppgitte tiltrekningsmomentene).

- S** Dom nationala riktlinjerna, angående officiell tillåtelse av tillbehör, måste bibehållas.

Dessa monterings- och användningsinstruktioner måste bifogas i fordonens dokumenten.

Bosal kan inte ställas till ansvar för fel på produkten som orsakats av användaren eller genom omdömeslöst bruk av produkten av användaren eller en person som han bär ansvar för (art. 185, paragraf 2 i den nederländska civilrättsbalken).

Vid leveransen vi kontrollerar alla våra produkterna med användningen av ett viktkontroll-system. I fall av frånvarande beståndsdelarna, vi har endast råd till att acceptera önskingar om ersättning, om du framvisar etiketten, som intyger förekomsten av viktkontrollen.

Det är nödvändigt att dra åt bultarna igen efter ungefär 1000 km körning (enligt angivna momentangivelser).

**FIN** Asennuksessa on noudatettava virallisia lisävarusteiden asennusta koskevia määräyksiä.

Asennus ja huolto-ohjeet on hyvä tallettaa ajoneuvon asiakirjoihin.

Bosalia ei voida pitää vastuullisena aine- tai henkilövahingoista, jotka johtuvat virheellisestä asennuksesta tai vääränlaisesta käytöstä (artikla 185 kohta 2, NBW).

Toimituksen yhteydessä kaikki tuotteemme tarkistetaan painontarkistusjärjestelmällä. Osien puuttuessa korvauspyyntö otetaan vastaan vain painontarkistuksen todistavan tarran esittämisen jälkeen.

Tuhannen kilometrin jälkeen kiristys on tarkistettava.

**I** Le norme nazionali per l'omologazione dei dispositivi di traino montati sui veicoli debbono essere rispettate.

Le istruzioni di montaggio e di utilizzo del dispositivo di traino devono essere allegate ai documenti del veicolo.

La Bosal declina ogni responsabilità per errato o imperfetto montaggio del dispositivo di traino, come pure per uso errato o improprio dello stesso.

Tutti i nostri prodotti sono controllati al momento della spedizione con un sistema di controllo peso. In caso di parti mancanti si accettano richieste di sostituzione esclusivamente con l'etichetta di controllo peso. Verificare il serraggio di tutti i bulloni dopo i primi 1000 Km. di traino.

**CZ** Musí se dodržet předpisy daného národního řízení ohledně úředního povolení doplňků.

Tyto předpisy instalace a provozu musí být v každém případě připojené k dokumentům vozidla.

Firma Bosal nenes zodpovědnost za jakoukoliv závadu na výrobku způsobenou nesprávným zacházením ze strany uživatele nebo další zodpovědné osoby.

Při dodávce jsou všechny naše výrobky kontrolované systémem pro kontrolu váhy. V případě doplnění chybějícího náhradního dílu žádost na dodávku máme možnost přijmout pouze po prokázání nálepky o potvrzení kontroly váhy.

Po ujetí zhruba 1000 km dotáhnout všechny šrouby a matice na výše uvedené hodnoty utahovacího momentu.

**PL** Należy zachować standardowo przypisane punkty mocowania.

Należy przestrzegać krajowych norm w zakresie pozwoleń na akcesoria.

Niniejszą instrukcję montażu należy dołączyć do dokumentów pojazdu.

Bosal nie bierze na siebie odpowiedzialności za uszkodzenia powstałe w wyniku nieodpowiedniego użytkowania przez użytkownika lub osoby podlegającej pod użytkownikowi (art.185 lid N.B.W.)

Podczas transportu wszystkie produkty sprawdzamy za pomocą systemu kontroli ciężaru. Prośby dotyczące uzupełnienia brakujących części przyjmujemy za okazaniem winiety potwierdzającej kontrolę ciężaru.

Po przejechaniu około 1000 km należy ponownie dokręcić śruby i nakrętki odpowiednim momentem.



**H** Be kell tartani a tartozékok hivatalos jóváhagyására vonatkozó nemzeti irányelveket.

Ezt a szerelési és üzemeltetési utasítást csatolni kell a jármű okmányaihoz.

A Bosal nem vonható felelősségre a termékben bekövetkező olyan károk esetén, amelyeket a felhasználó vagy az ő felelőssége alá tartozó személy mulasztása vagy gondatlan használata okozott. (185. §, 2. bekezdés, N.B.W.)

Valamennyi termékünket súlyellenőrző rendszerrel vizsgáljuk meg a feladáskor.  
Hiányzó alkatrészek esetében csak a súlyellenőrző címkével fogadunk el cserére vonatkozó kérést.

Kb. 1000 km használat után húzza meg újra a csavarokat és a csavaranyákat az előírt nyomatékra.

1

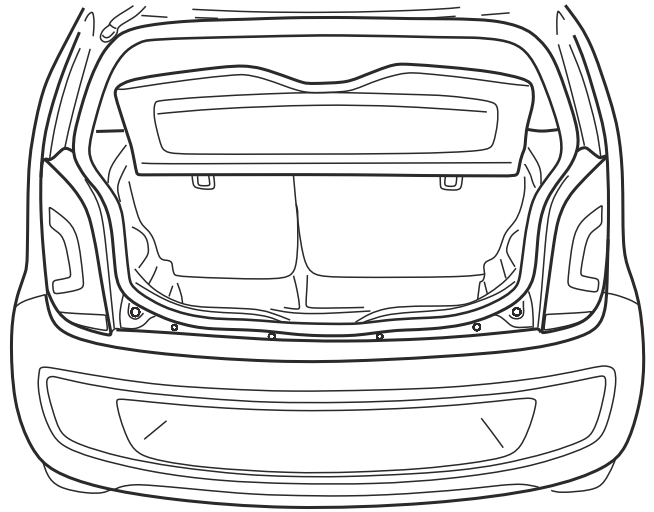
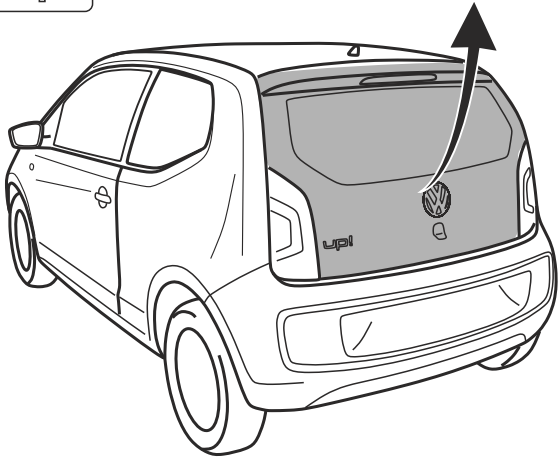

2

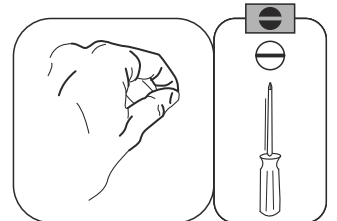
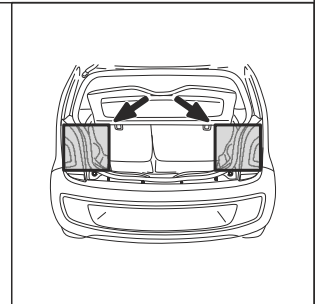
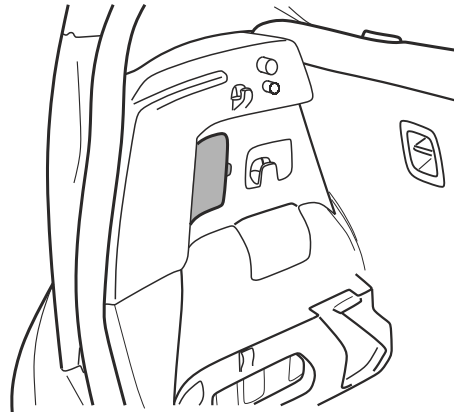

3

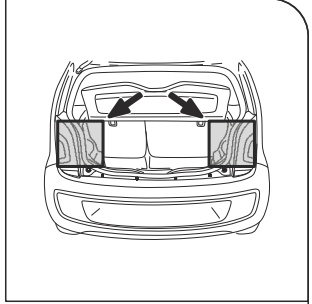
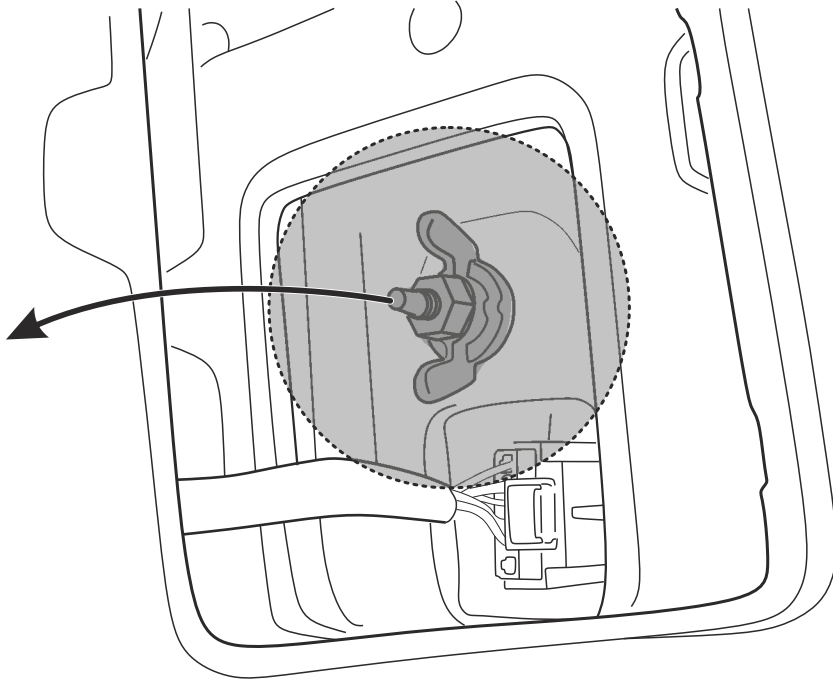

4

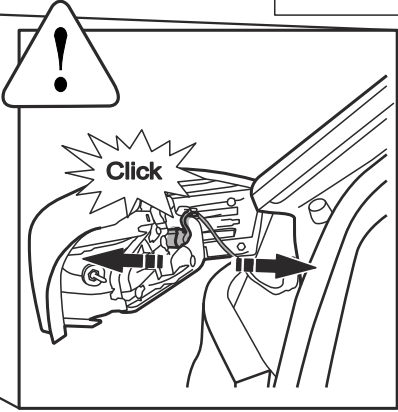
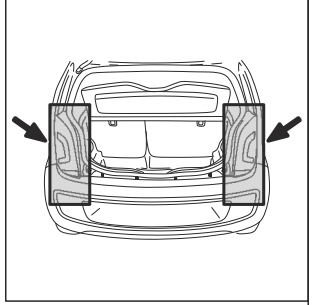
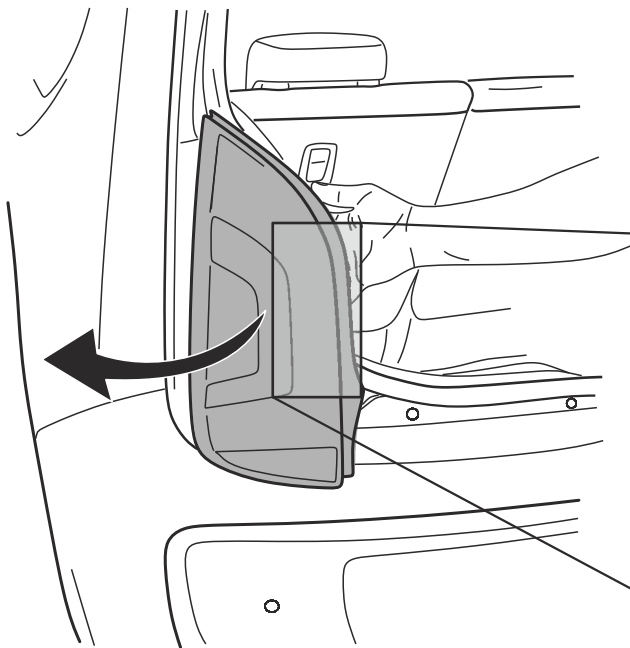

5

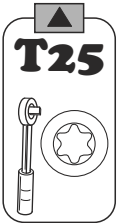
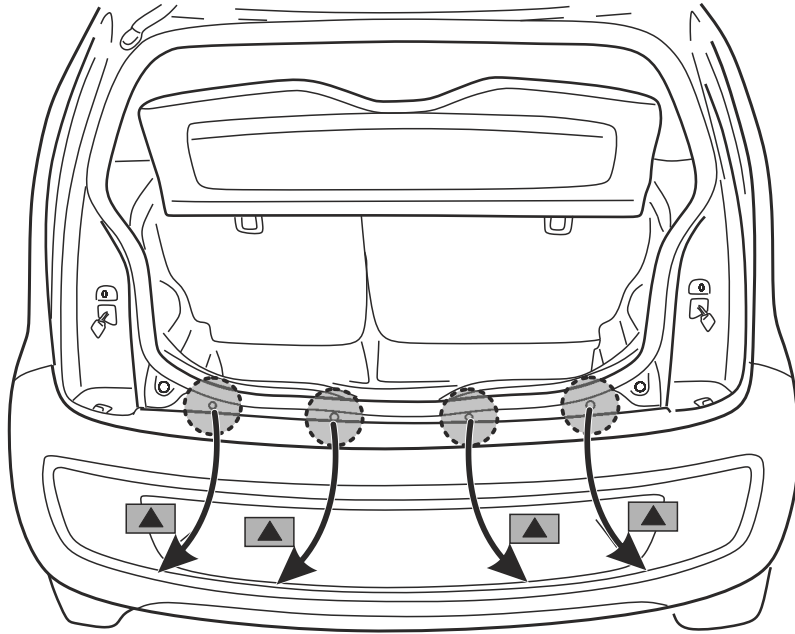

6

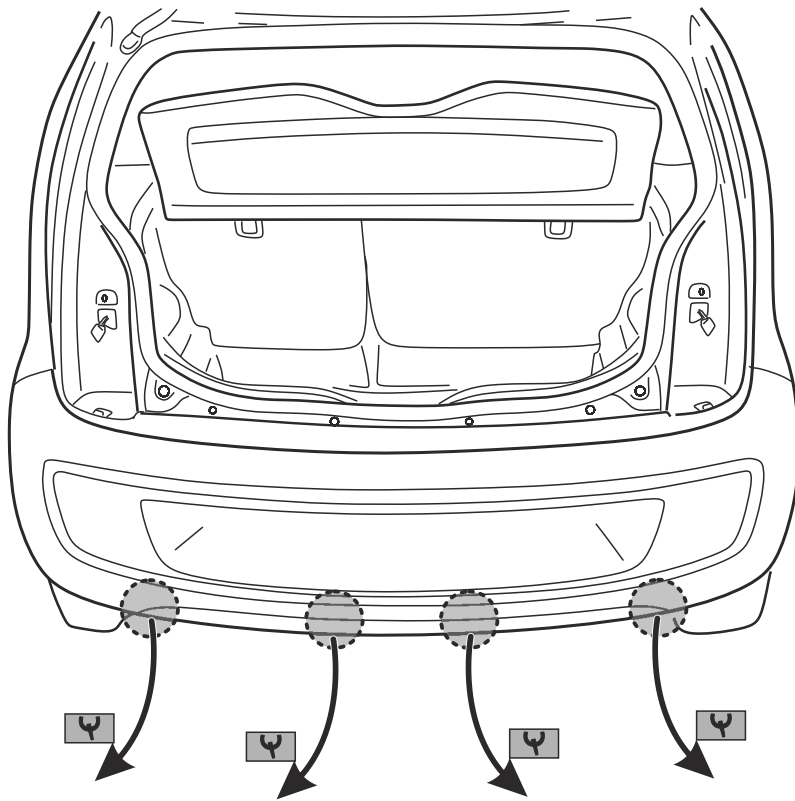
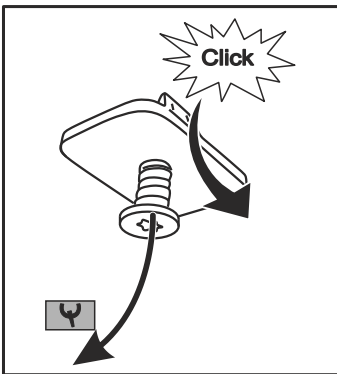

7

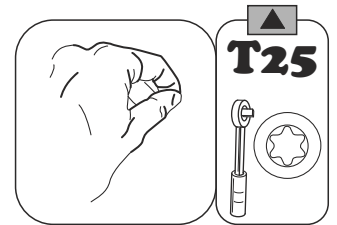
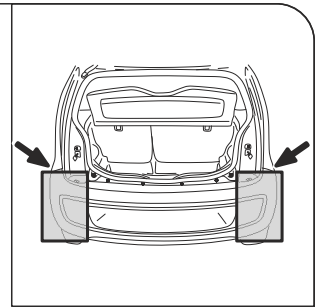
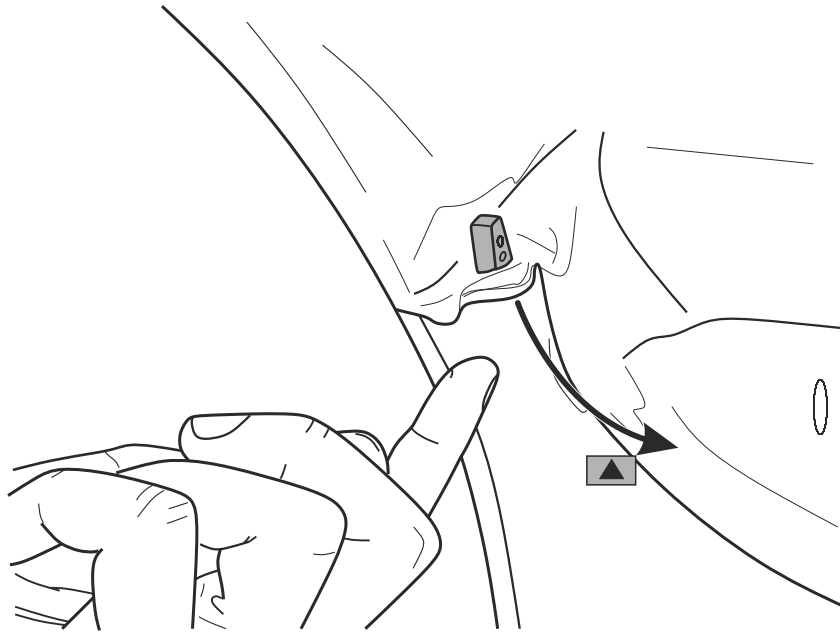

8

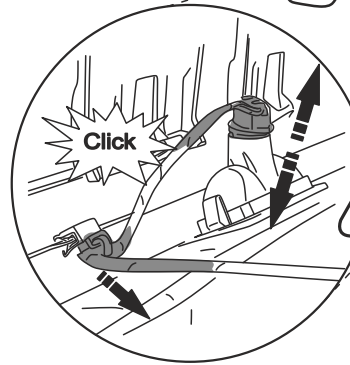
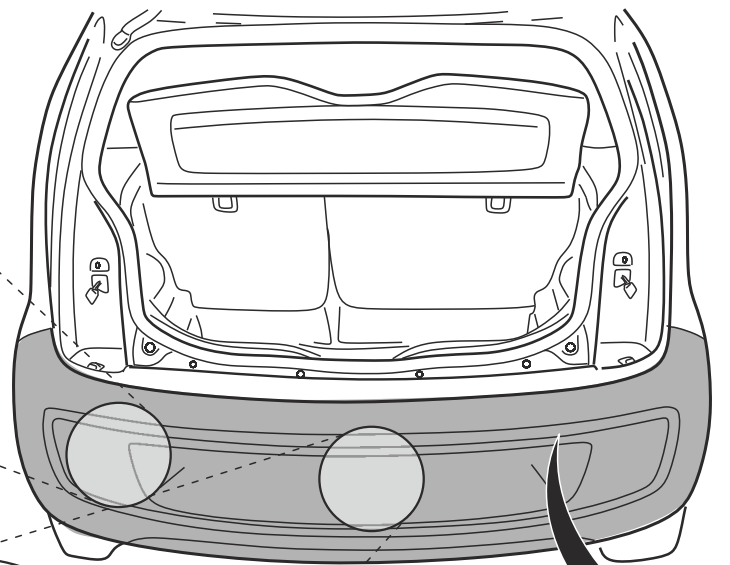

9

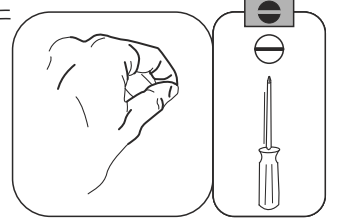
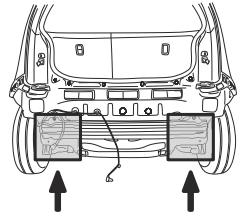
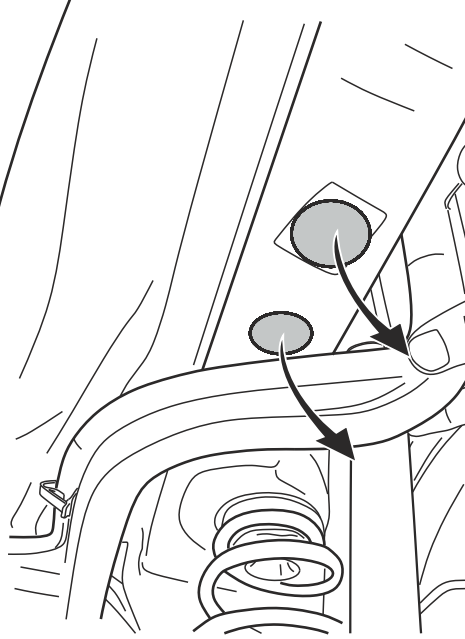
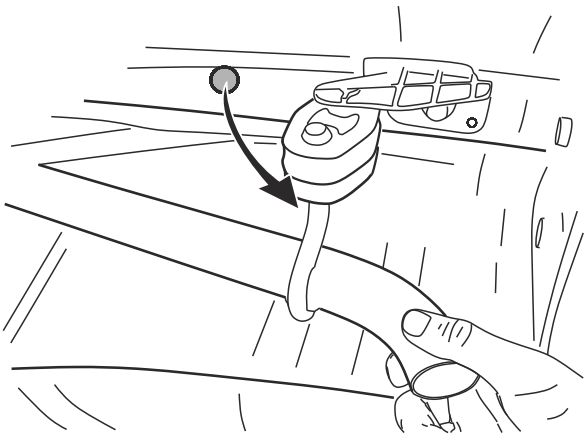

10

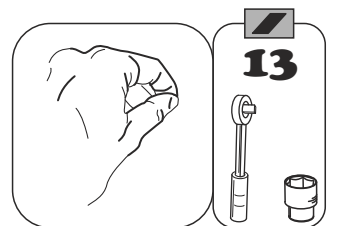
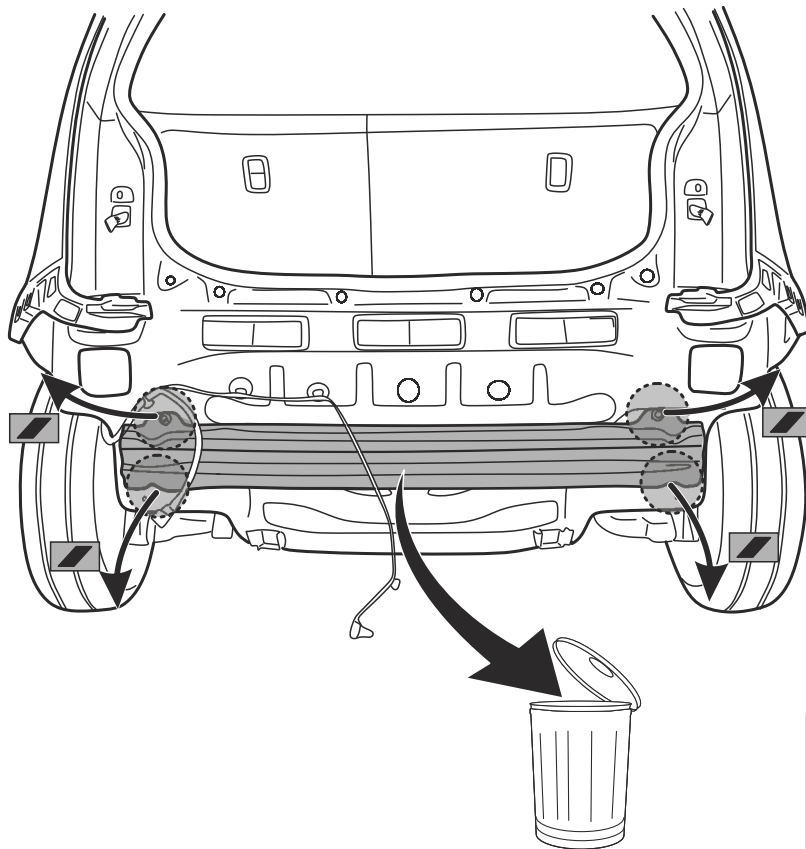

14

11

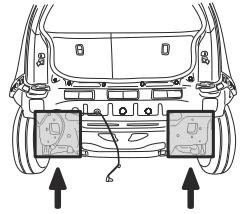
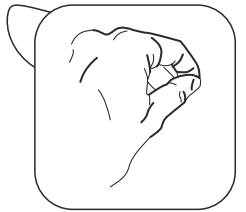
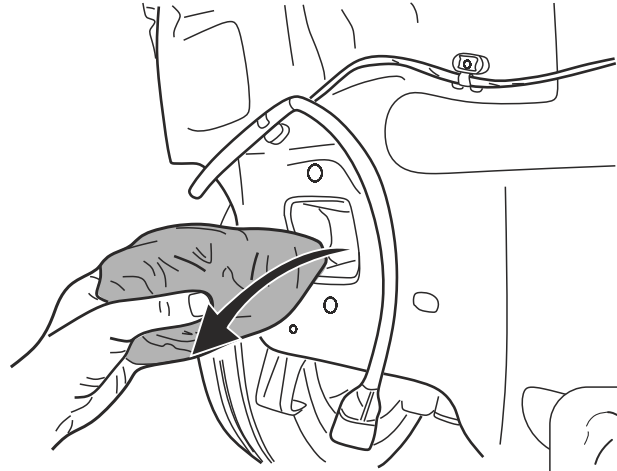
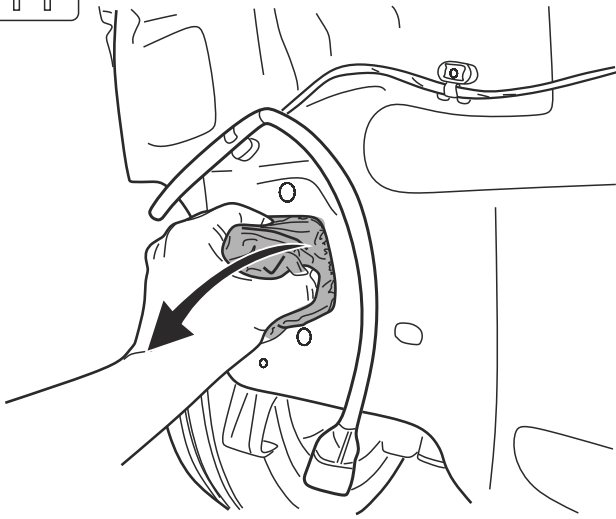

12

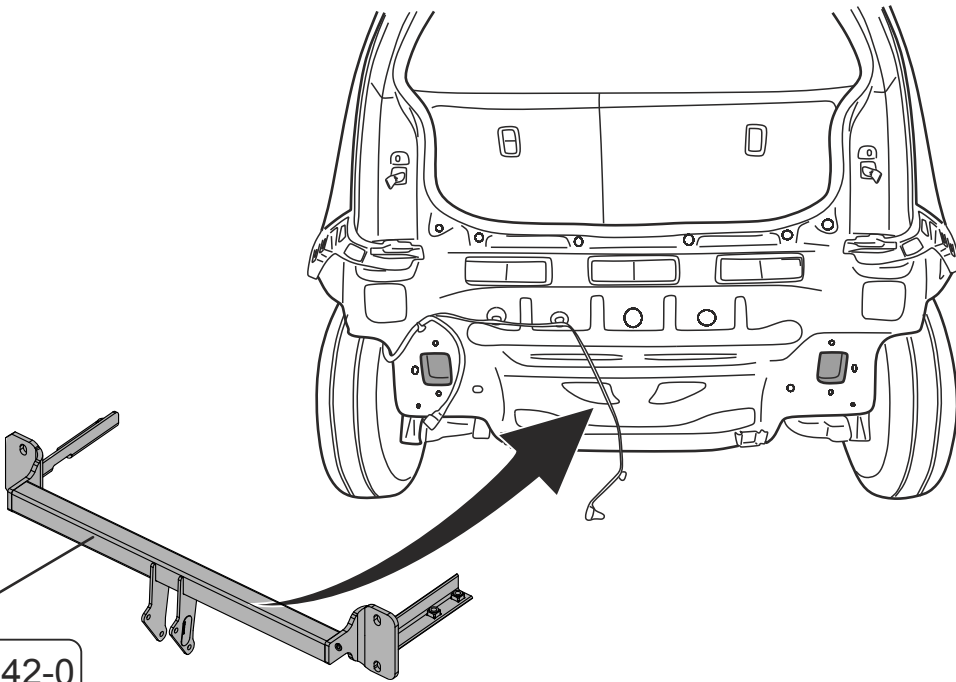

1 3842-0

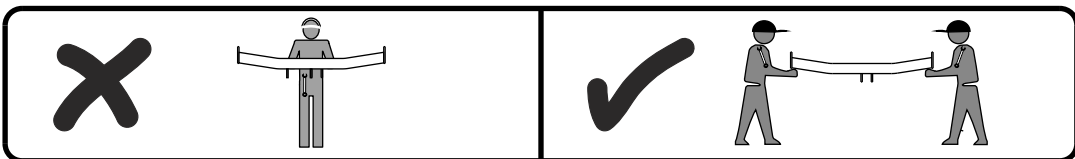

13

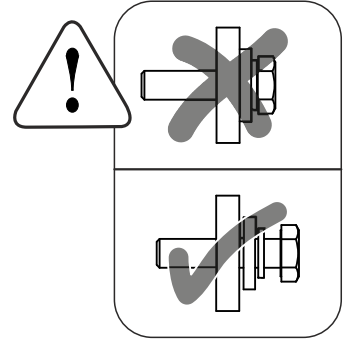
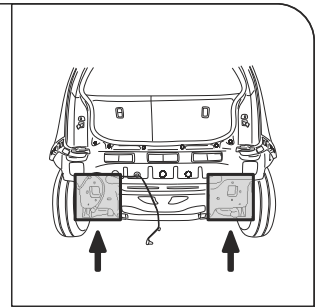
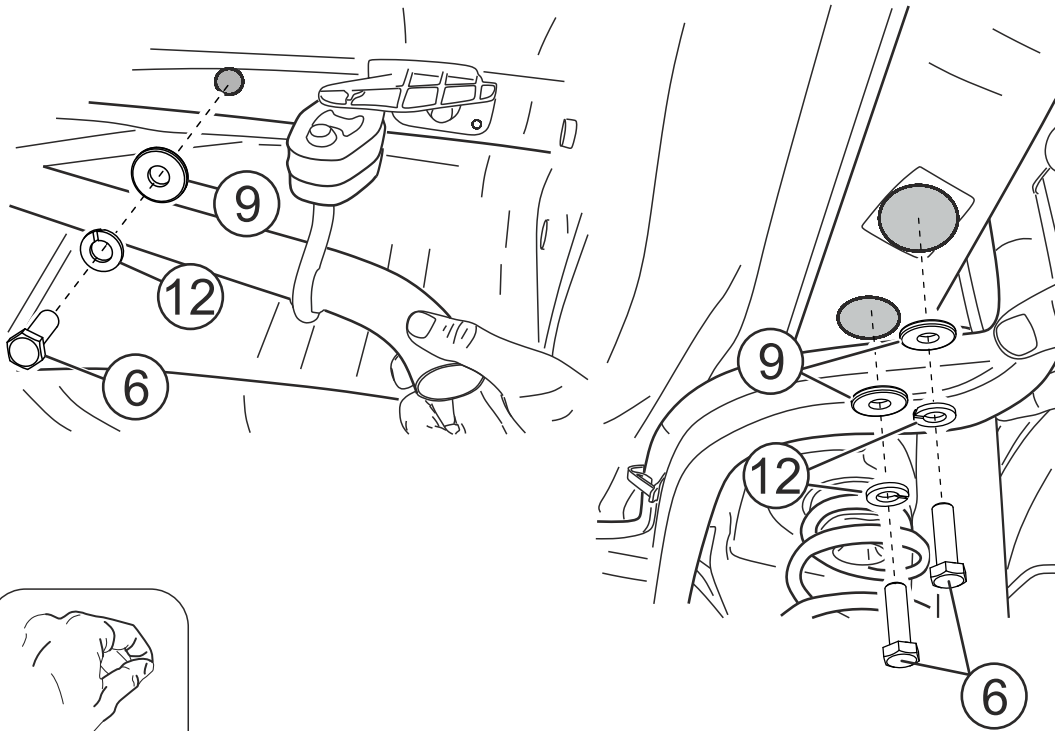

14

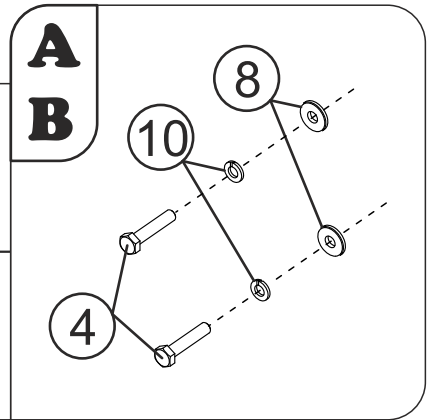
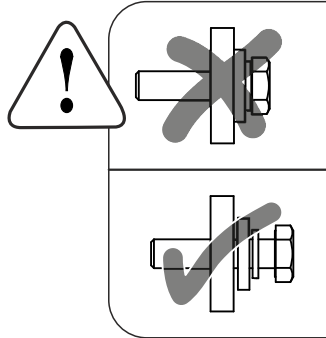
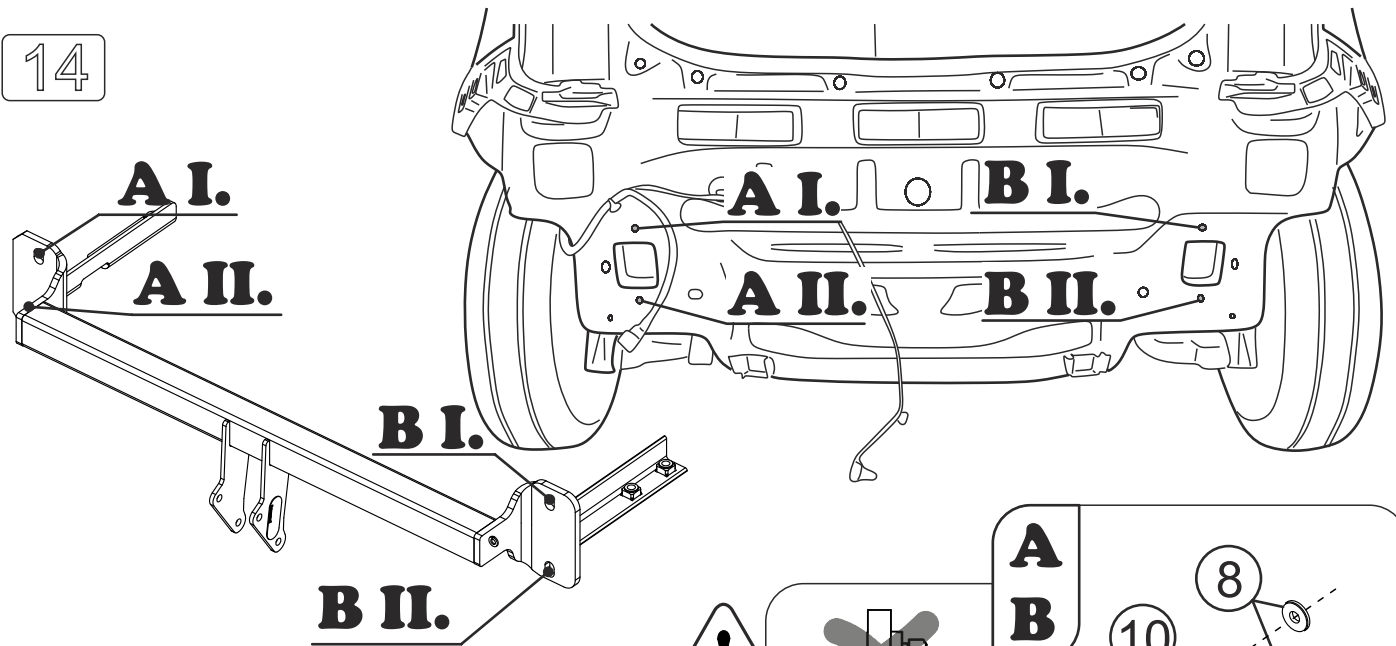

16



15

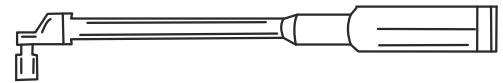
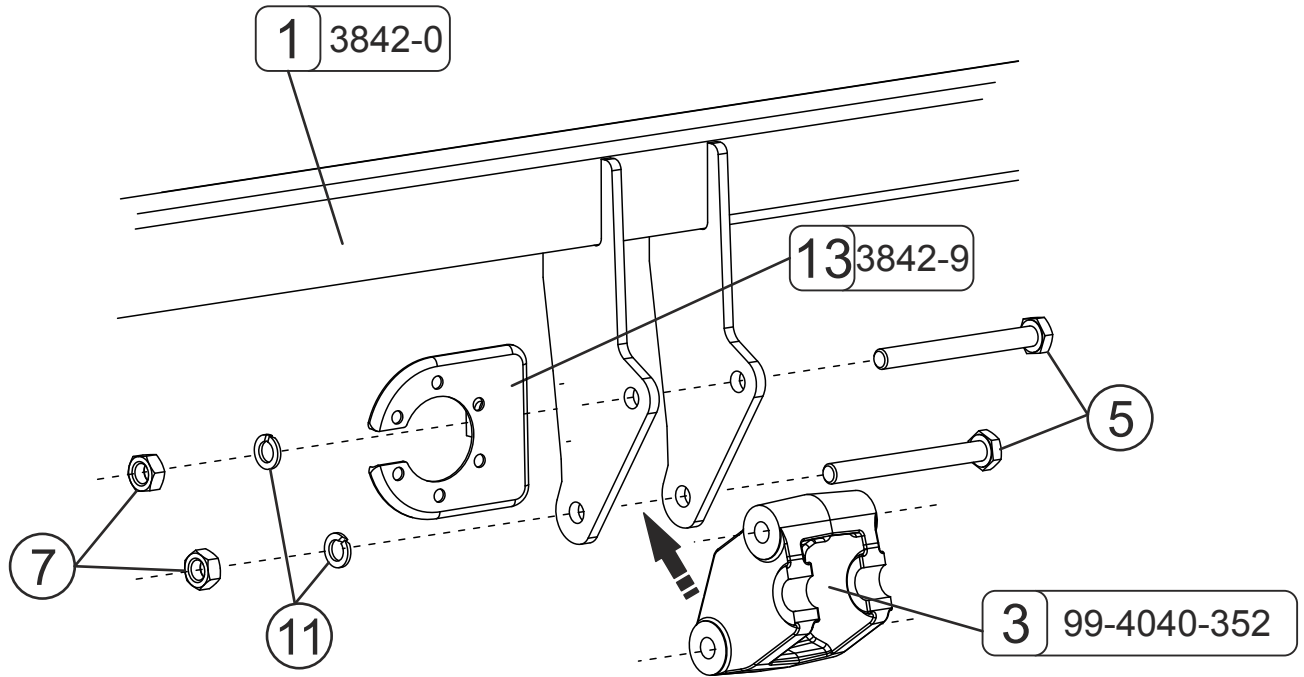

**17 M10 - 46 Nm**

16

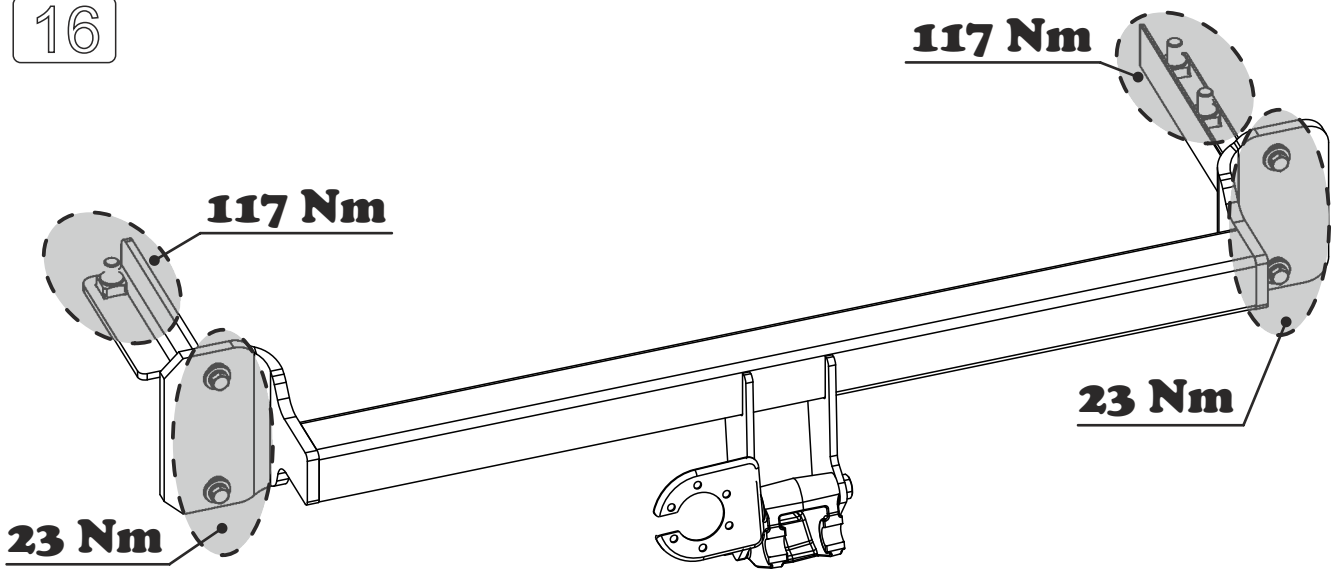

**13  
19**



**M8 - 23 Nm  
M12 - 117 Nm**

17

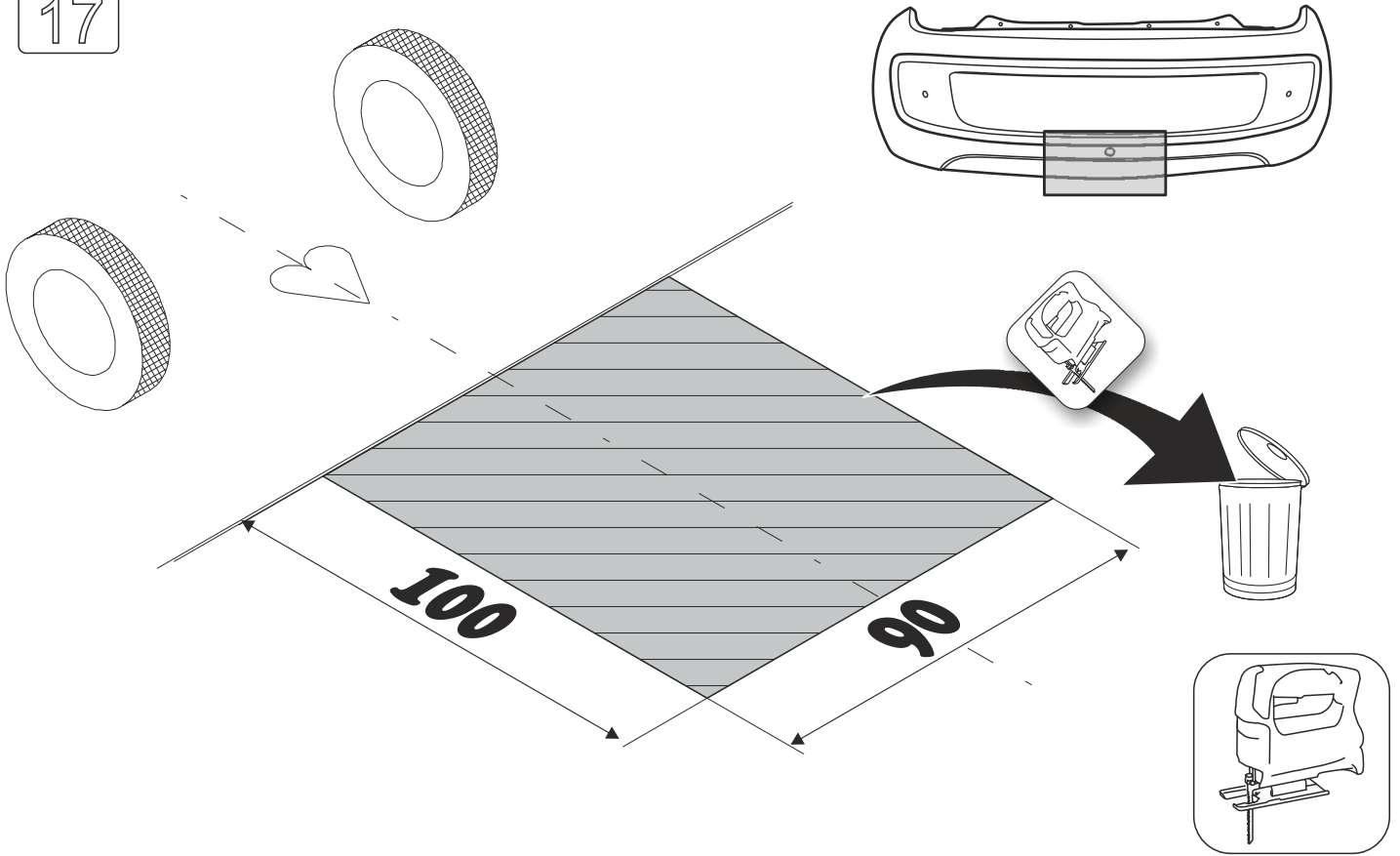

18

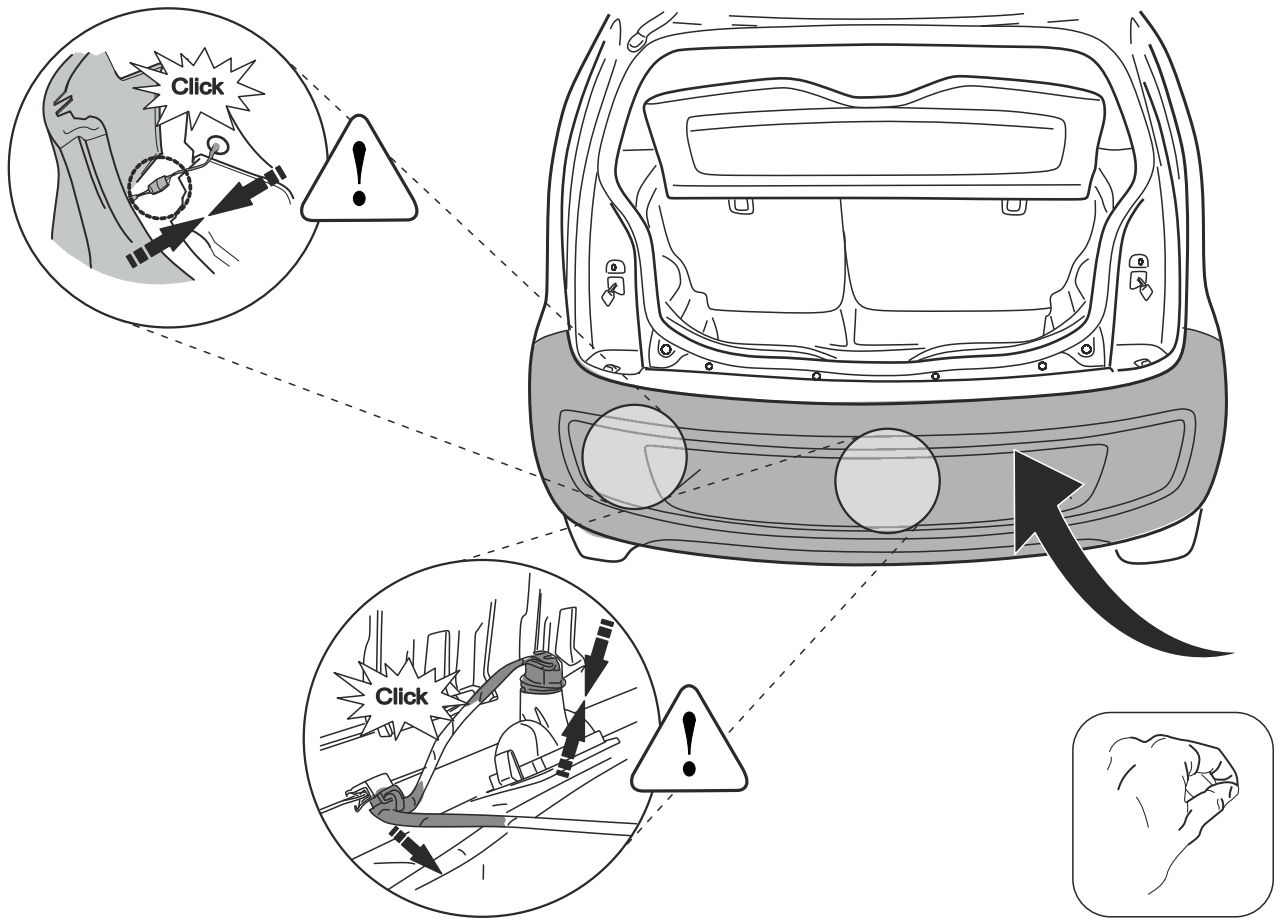

18

19

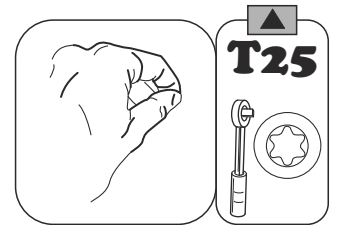
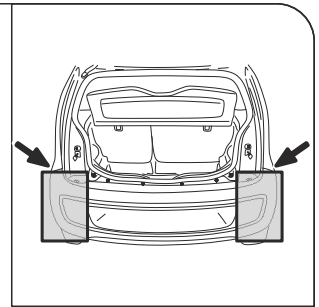

20

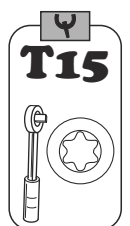
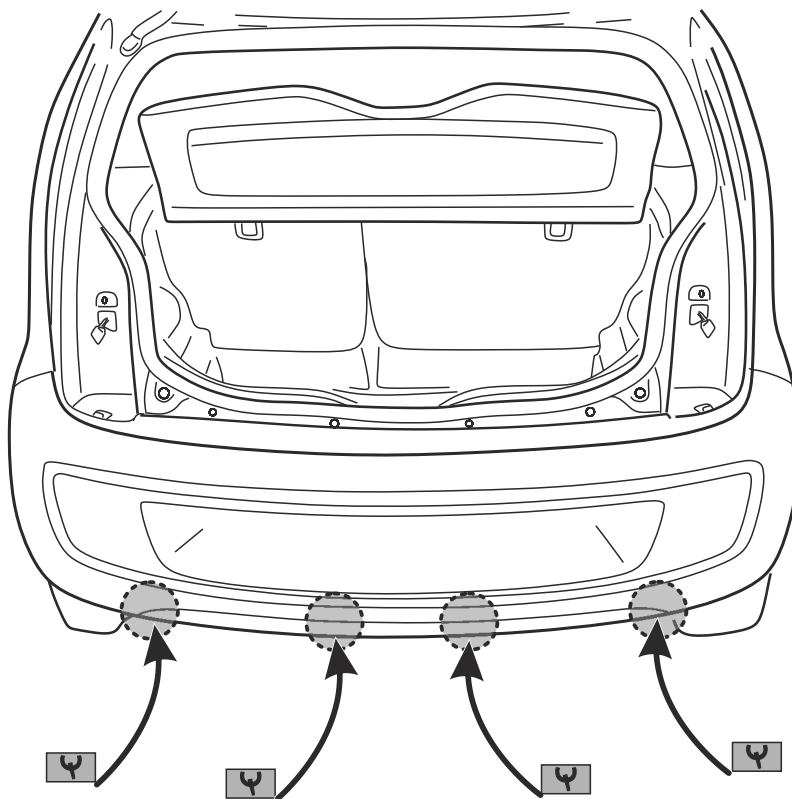
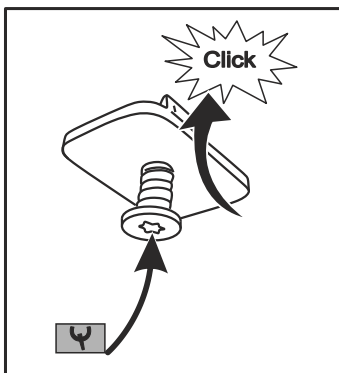

21

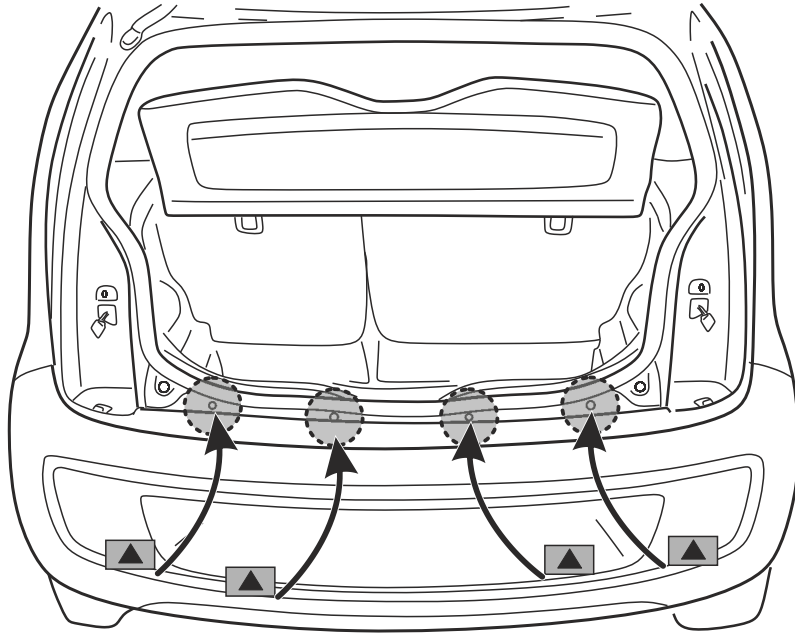

22

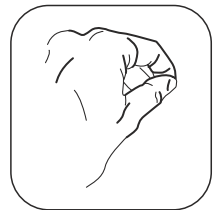
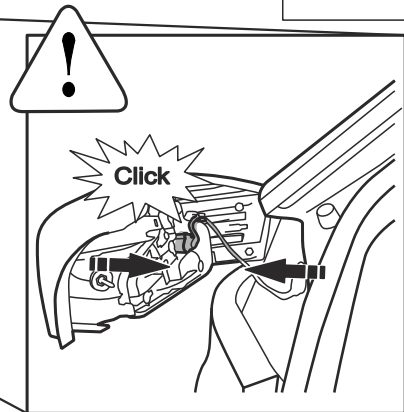
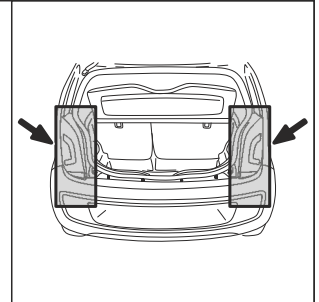
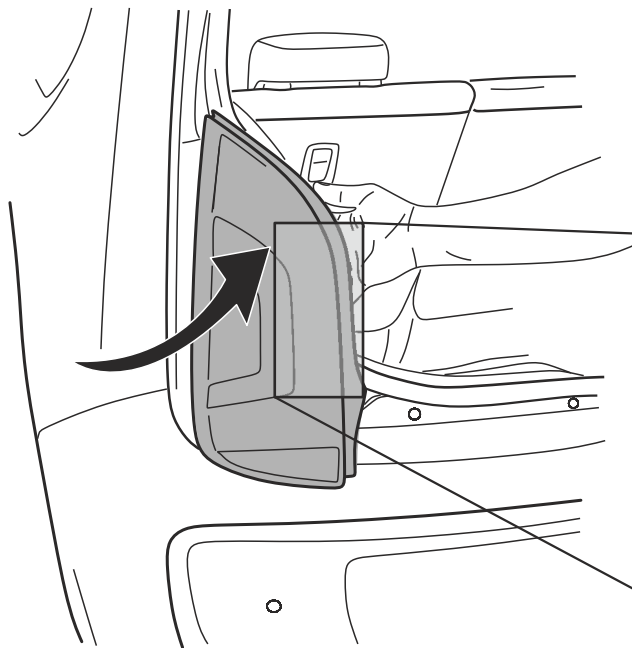

20

23

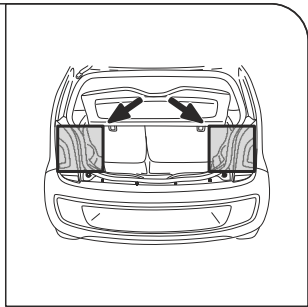
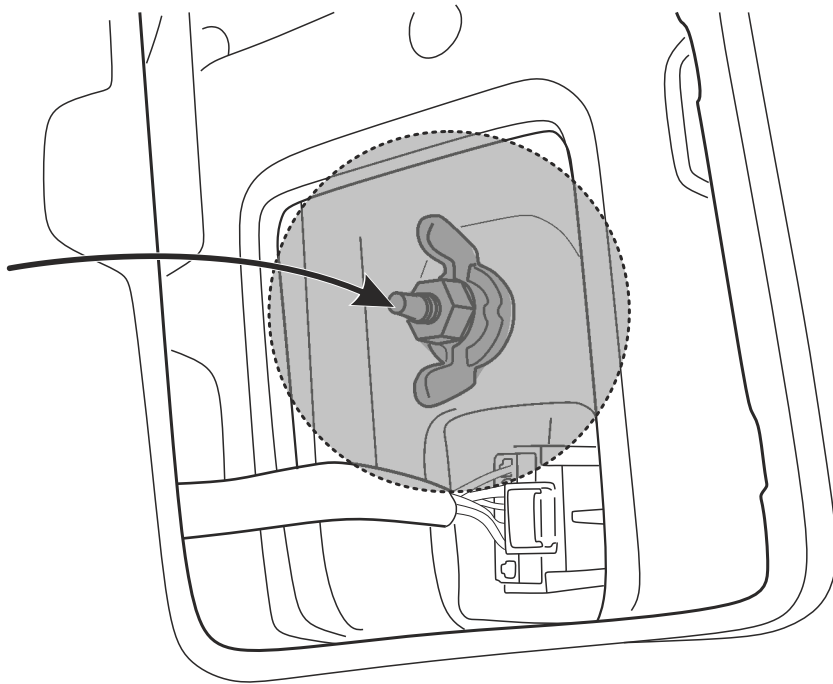

24

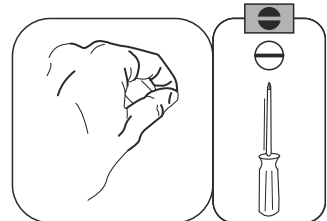
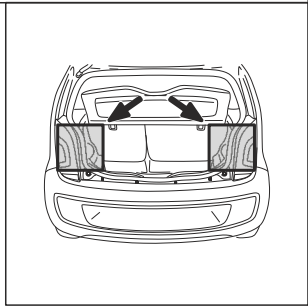

25

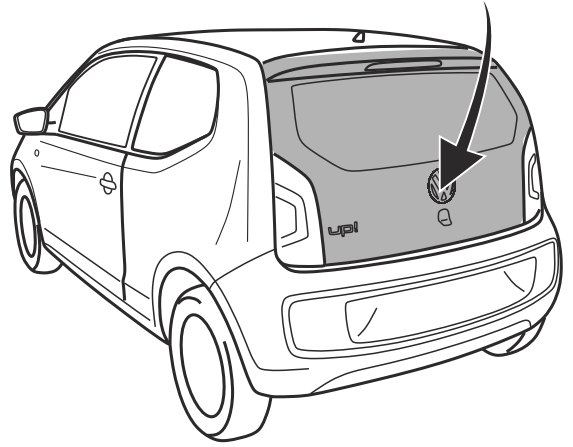
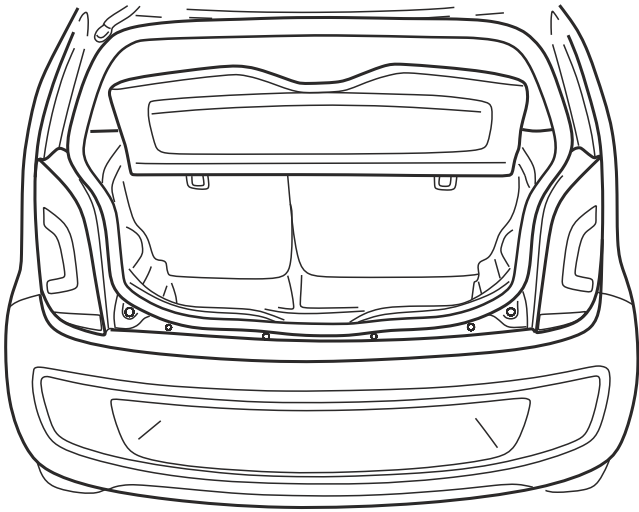

26

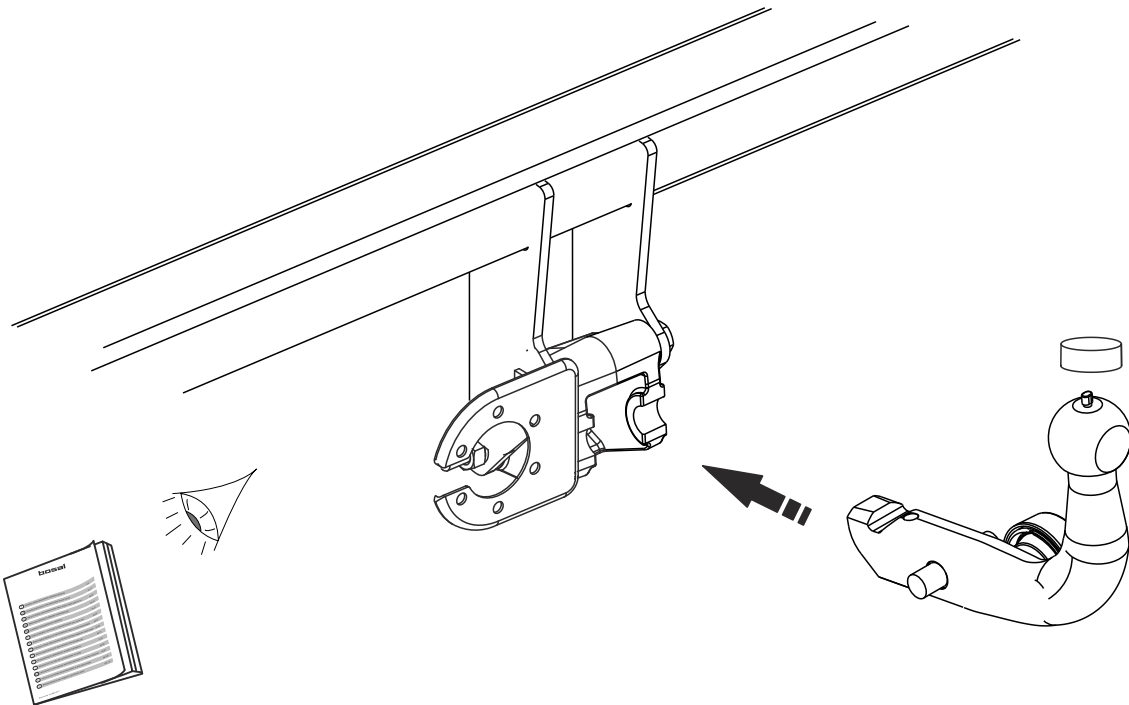

27

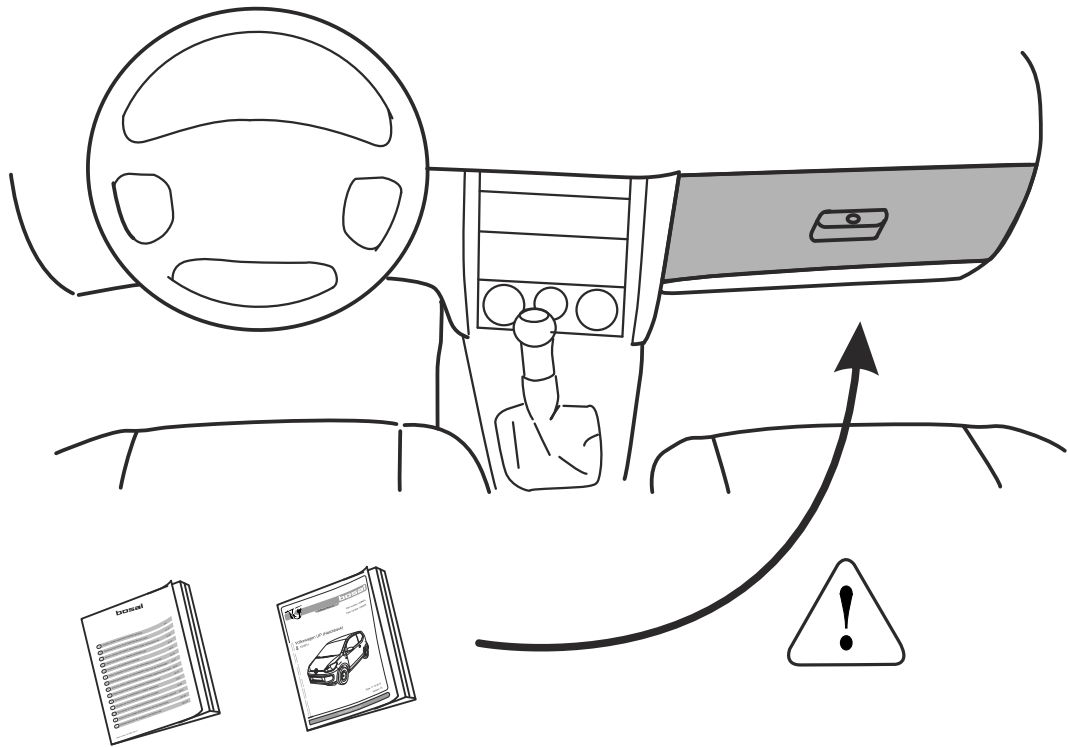

28

