

---

Fitting instructions

---

Make: Toyota

---

Yaris; 1999->

---

Type: 3889

---

---

Permanently

---

linked to

---

quality

---

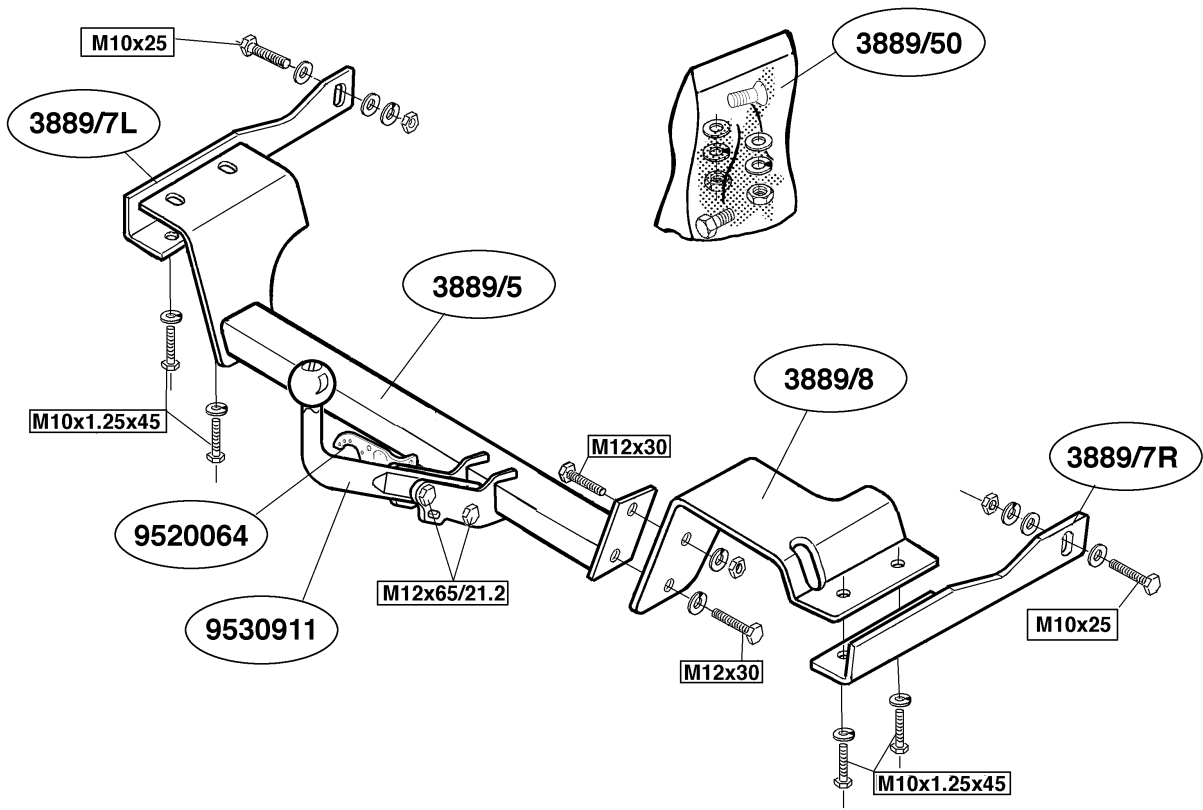

Tested in accordance with directives 94/20/EG

© 388970/26-09-2003/1

© 388970/26-09-2003/18

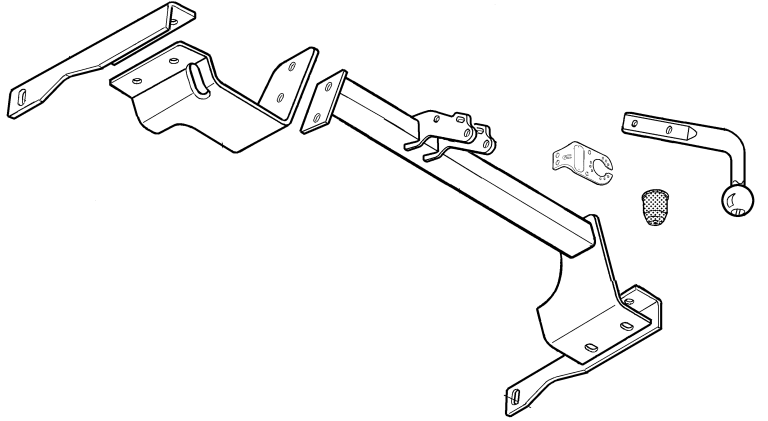

(2x) M10x25



(2x) M12x65/21.2



(4x) M10x1,25x45



(2x) M12x30



(2x) self-locking M12



(2x) M10



(1x) M12



(4x) M10



(2x) M12



(6x) M10



(2x) M12



(2x) plastic cap



(2x) 5x10

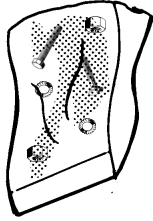

tipo:.....  
Il dispositivo di attacco sopra indicato è stato installato su autoveicolo  
modello:.....  
targa:.....  
Data:.....

TIMBRO e FIRMA

**DICHIARAZIONE DI CORRETTO MONTAGGIO:** la sottoscritta Ditta dichiara di aver montato in maniera corretta ed in conformità alle prescrizioni sia del costruttore del veicolo che del costruttore del dispositivo stesso il seguente dispositivo di attacco meccanico:

Si dichiara inoltre di aver informato l'utente del veicolo sull'USO e MANUTENZIONE del dispositivo stesso.

**DA COMPIRE PER IL COLLAUDO**

**Per verificare l'idoneità del dispositivo di traino omologato a norma CEE 94/20, all'installazione sulla vettura su cui si intende procedere al montaggio, compilare la seguente formula (se necessario) declassare la massa rimorchiabile):**

dove: T = Massa Complessiva Max. della motrice (in kg)  
C = Massa Rimorchiabile Max. della motrice (in kg)  
$$D = \frac{T + C}{T \times C} \times 0,00981 = \dots \text{ kN} > D$$

Dispositivo di traino tipo: Brink 3889  
Per autoveicoli: Toyota Yaris; 1999->  
Tipo funzionale:  
Classe e tipo di attacco: A50-X  
Omologazione: e11 00-4320  
Valore D: 6,0 kN  
Carico Verticale max. S: 50 kg  
Larghezza rimorchiabile per Caravan e T.A.T.S.: 2,45m vedere CARTA di CIRCOLAZIONE VEICOLO (motrice) + 70 cm = ..arrotondare ai 5 cm superiore (vedi D.M.28/05/85)  
Massa rimorchiabile: vedi carta di circolazione dell' autoveicolo

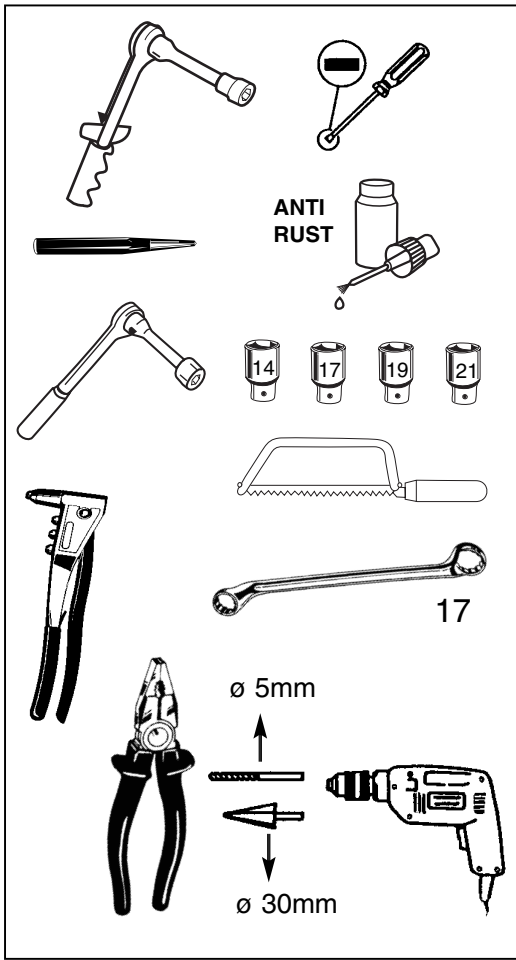

±5%

**D-value**

$$D = \frac{1380 \text{ k.G. max} \times 900 \text{ k.G. max}}{1380 \text{ k.G. max} + 900 \text{ k.G. max}} \times \frac{9.81}{1000} = 6,0 \text{ kN}$$

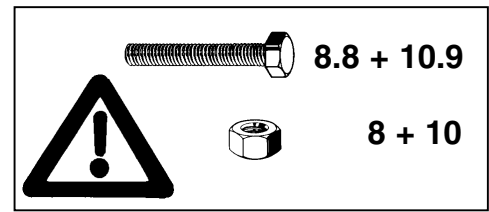
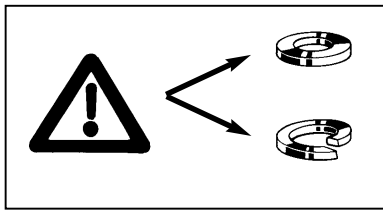
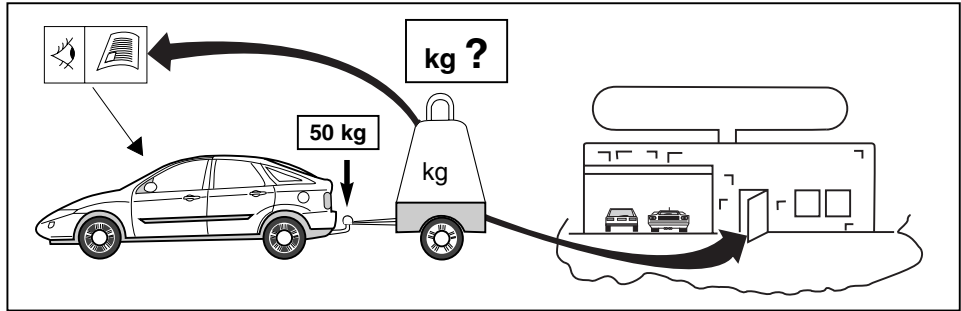

© 388970/26-09-2003/3

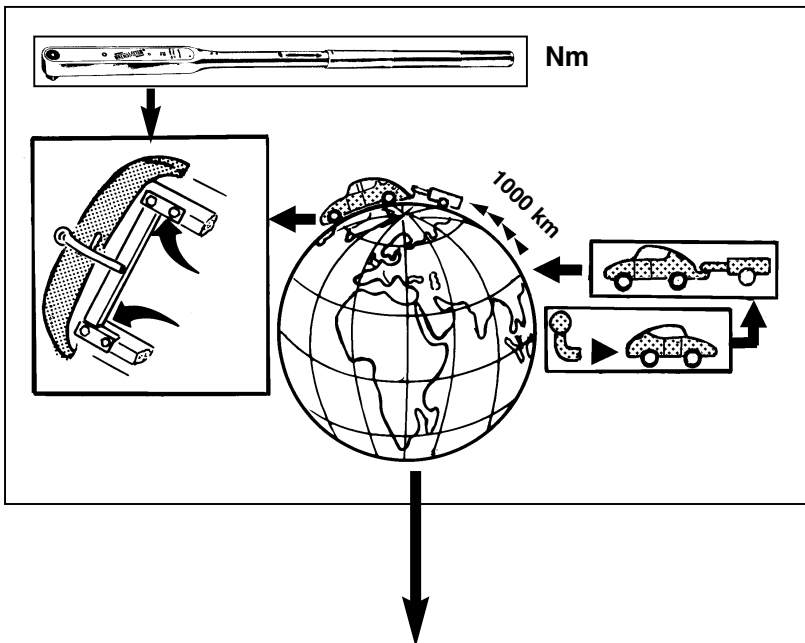

**D**

**ZU BEACHTEN:**

- \* Die für das Fahrzeug zugelassene Anhängelast ist den Fahrzeugpapieren zu entnehmen. Bei einem höheren Zugfahrzeuggewicht muß die höchstzulässige Anhängelast gegebenenfalls aus dem D-Wert nachgerechnet werden. Auskunft hierüber kann Ihr Fachhändler oder der TÜV geben.
- \* Elektrische Anlage gemäß StVZO anbringen.
- \* Der nachträgliche Einbau der Kupplungskugel mit Halterung nach dieser Anbauanleitung muß nach den (deutschen Zulassungsvorschriften (§21b StVZO) durch einen befugten Sachverständigen oder Prüfer unter Vorlage des Fahrzeugbriefes überprüft werden. Danach muß von der jeweiligen Zulassungstelle der Einbau in den Fahrzeugschein eingetragen werden.

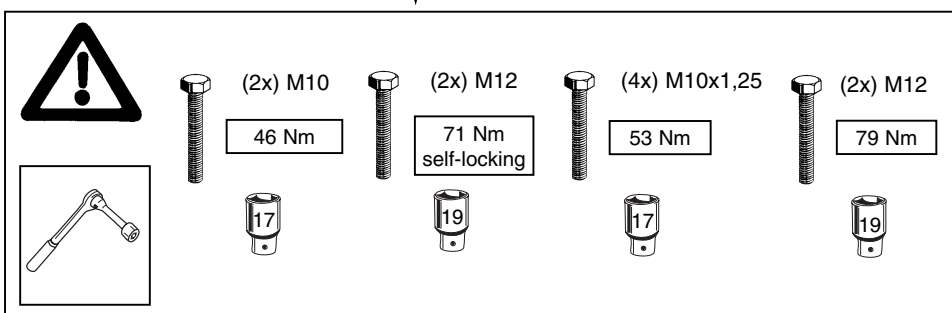

© 388970/26-09-2003/16

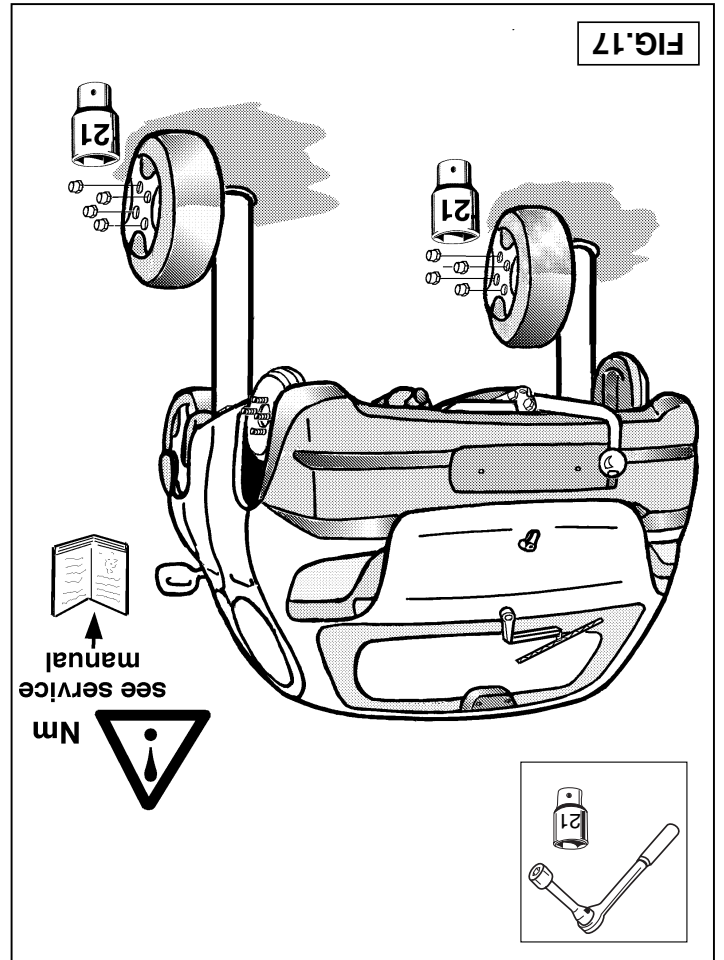
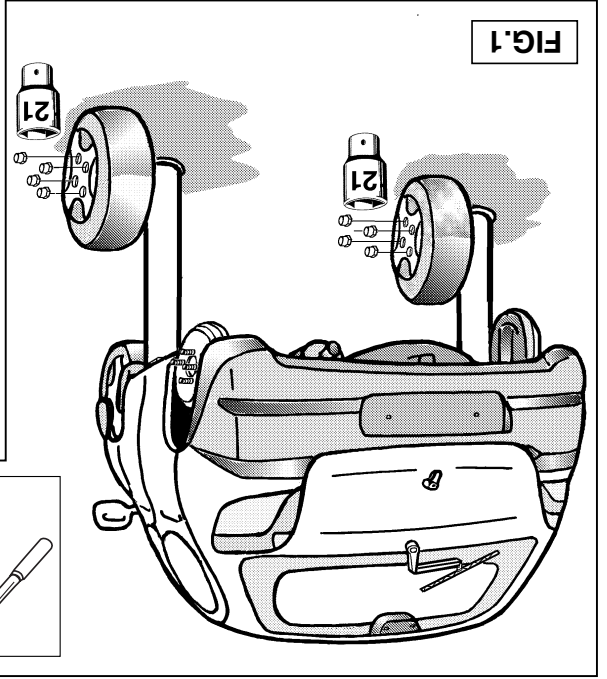
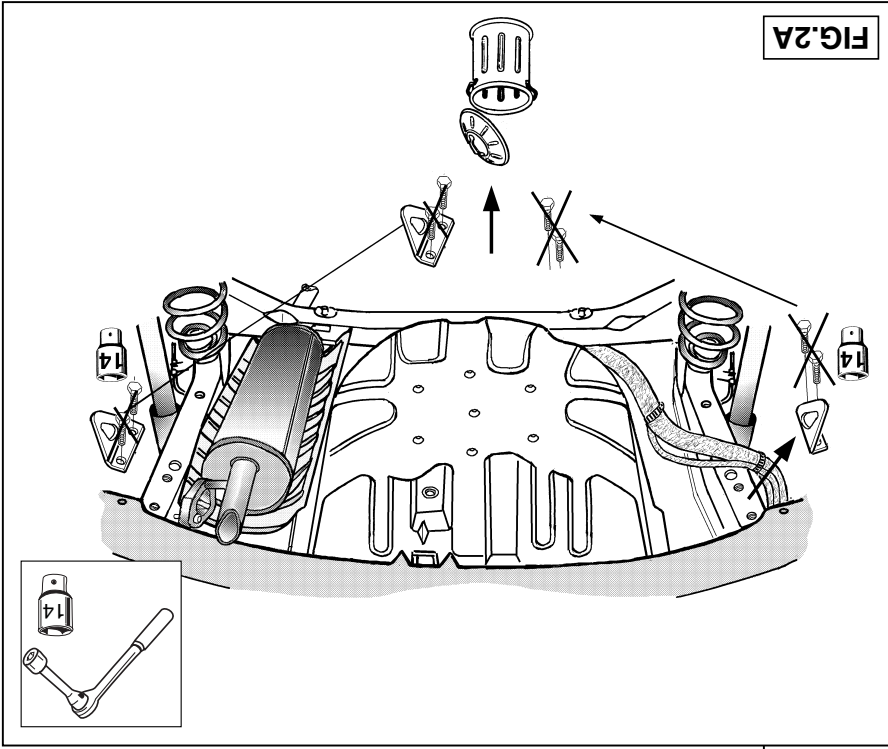

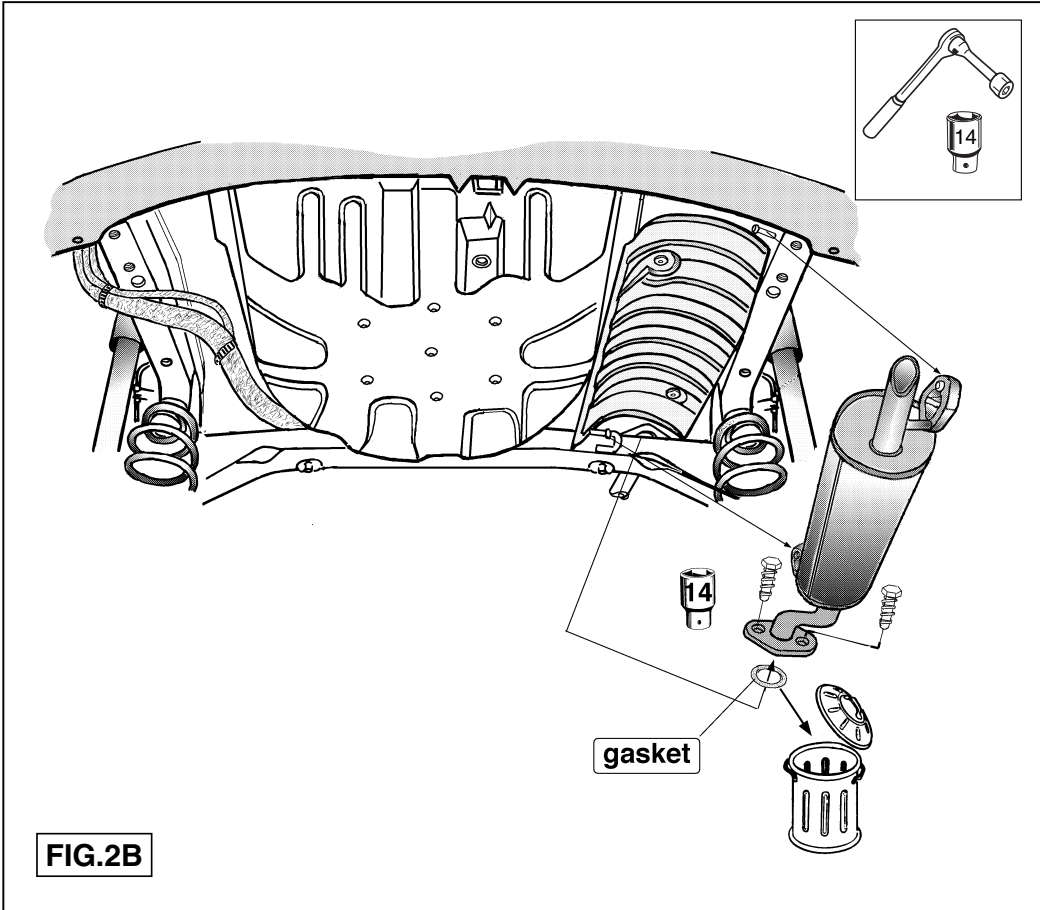

© 388970/26-09-2003/5

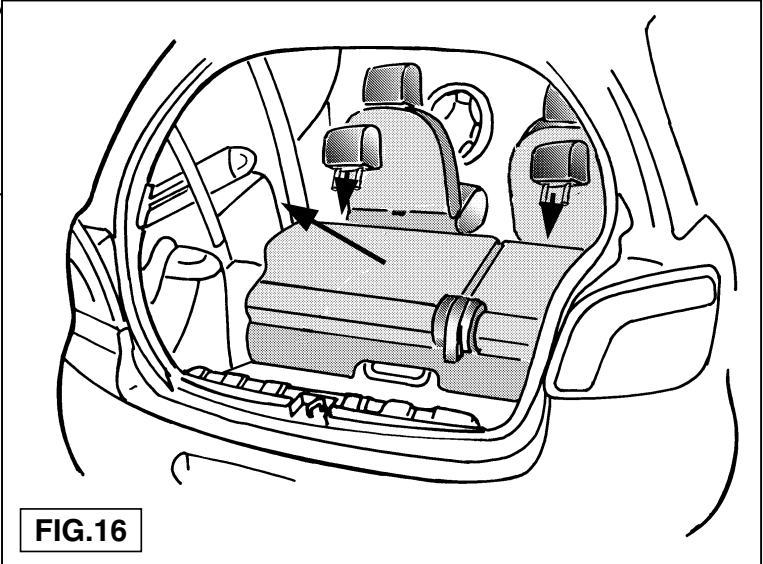
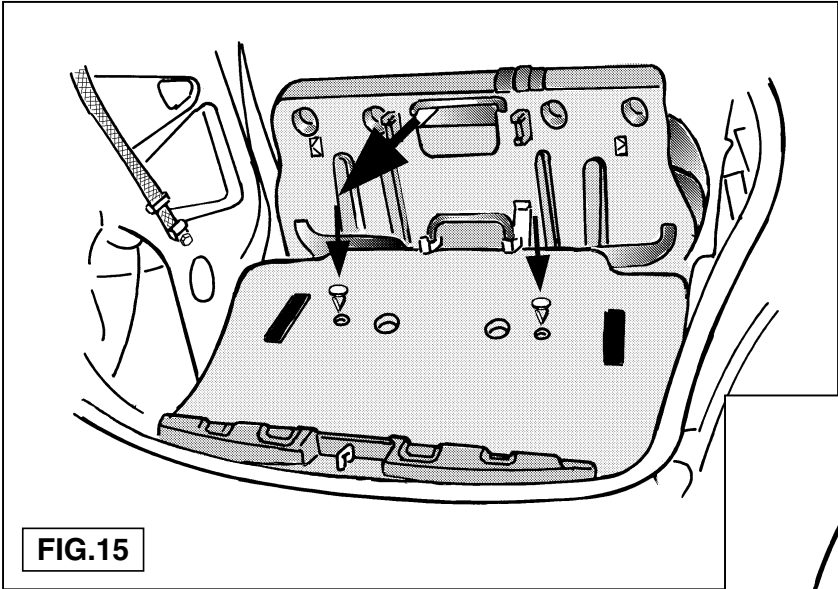

© 388970/26-09-2003/14

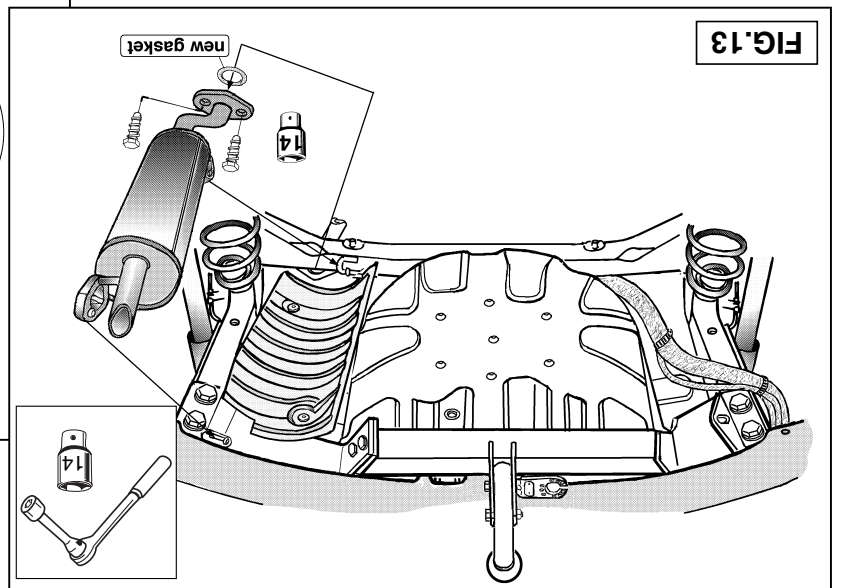
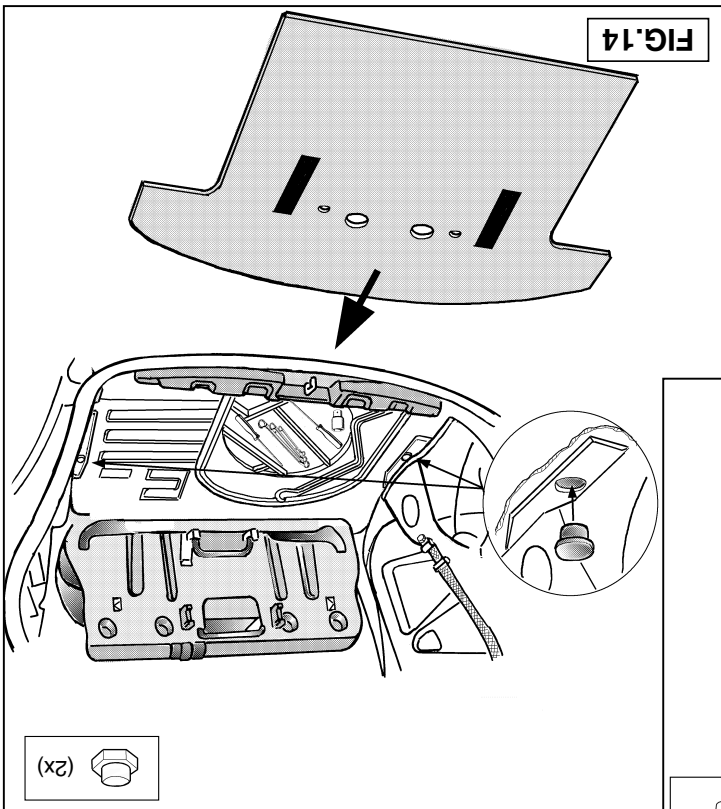
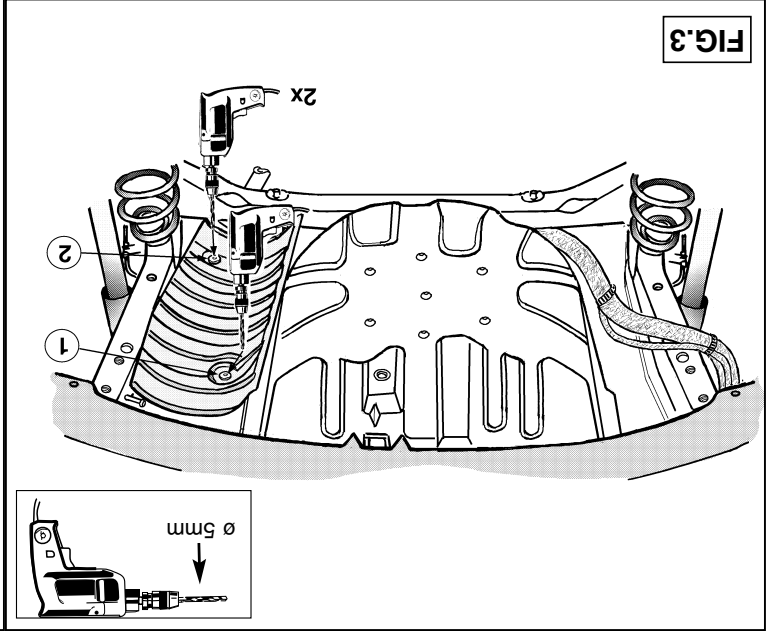
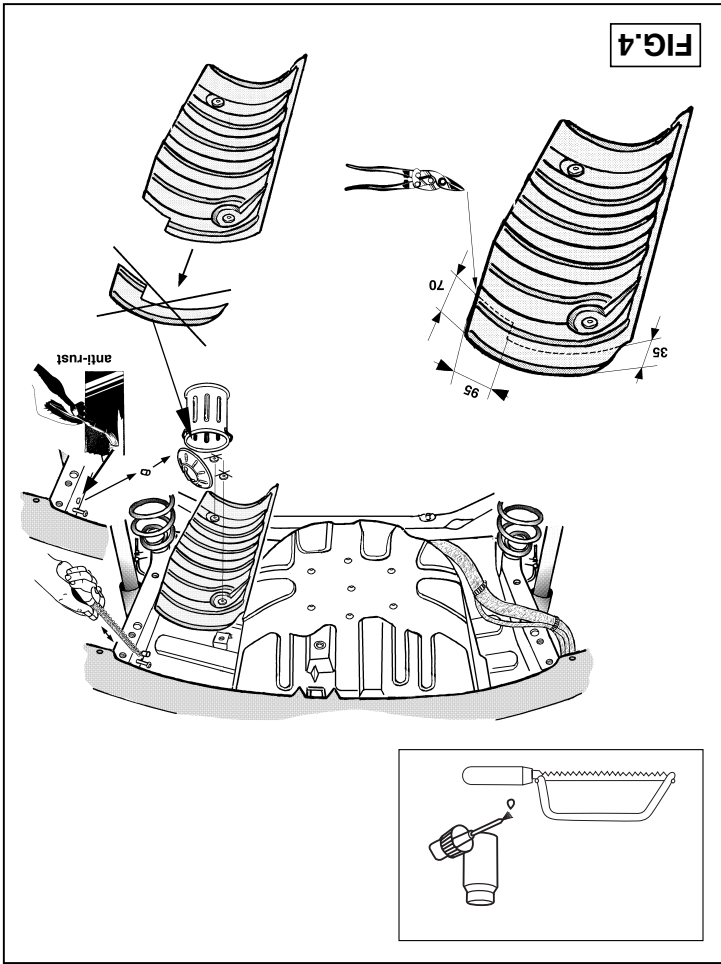

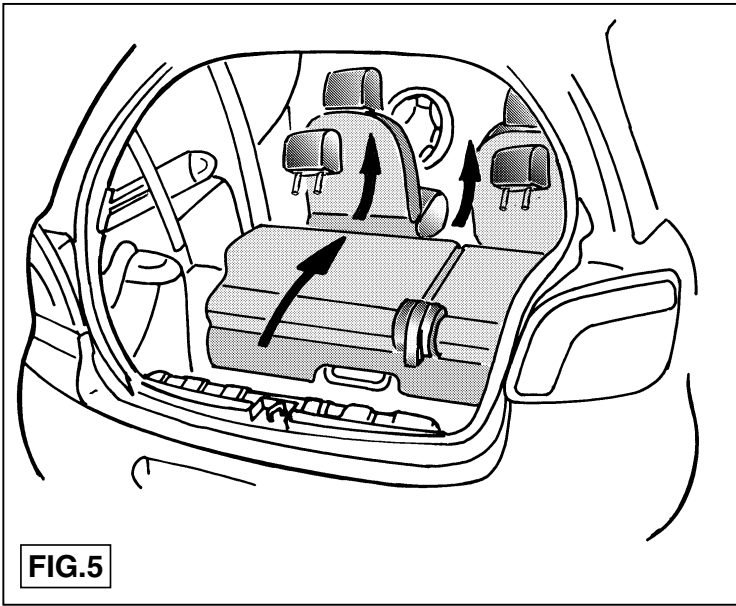

FIG.5

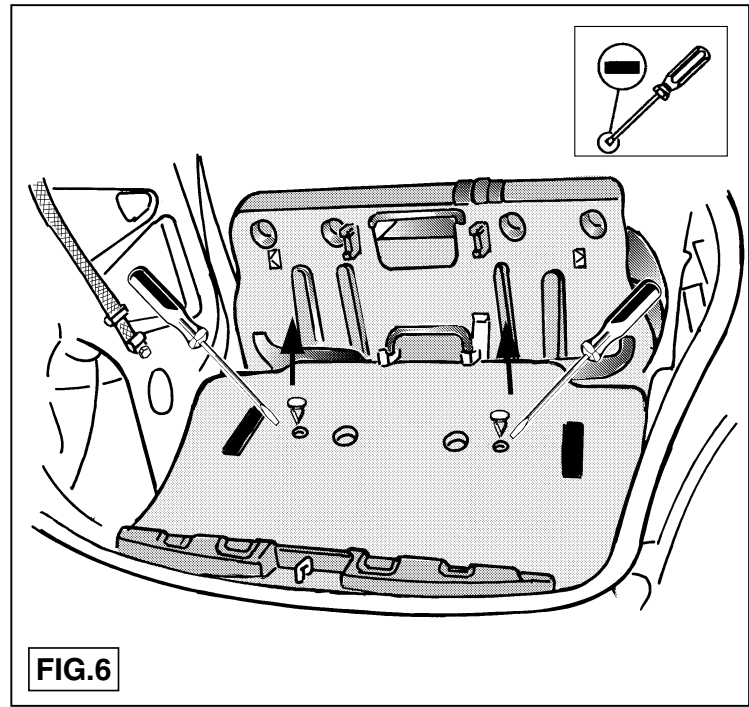

FIG.6

© 388970/26-09-2003/7

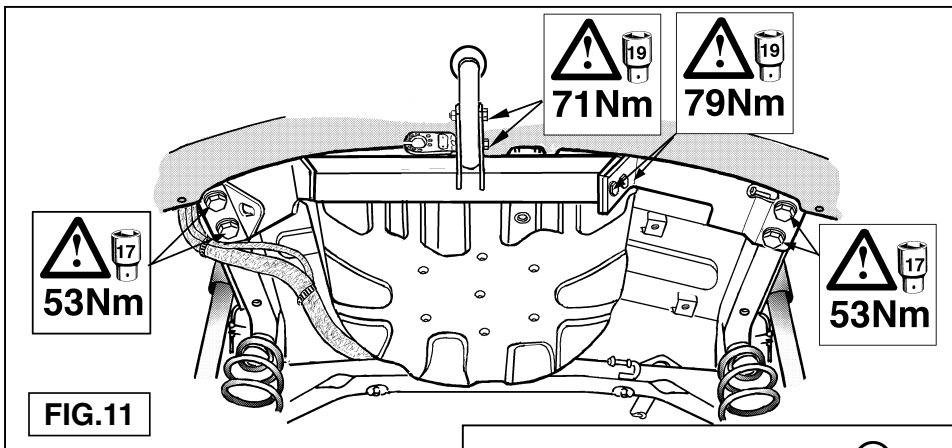

FIG.11

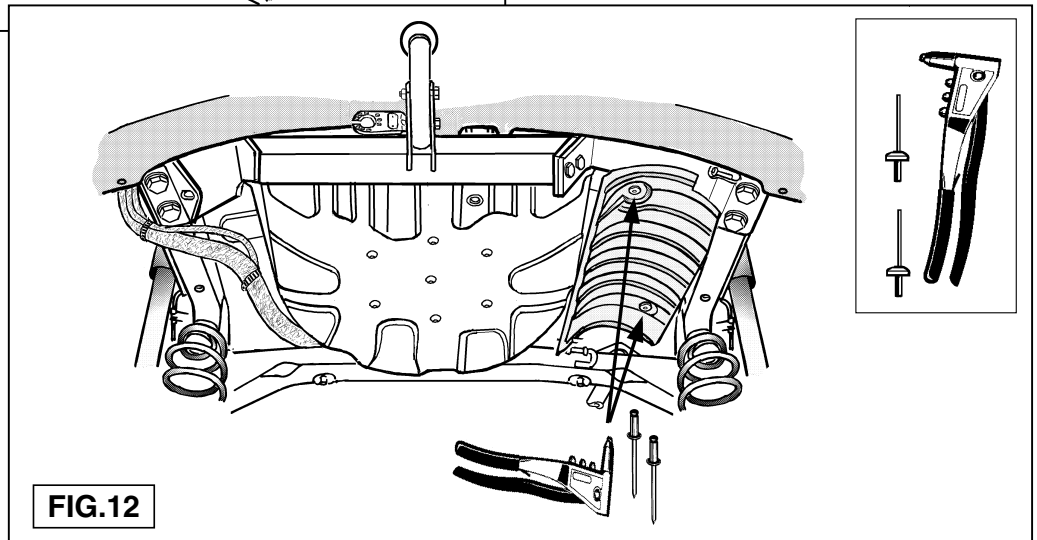

FIG.12

© 388970/26-09-2003/12



FIG.7

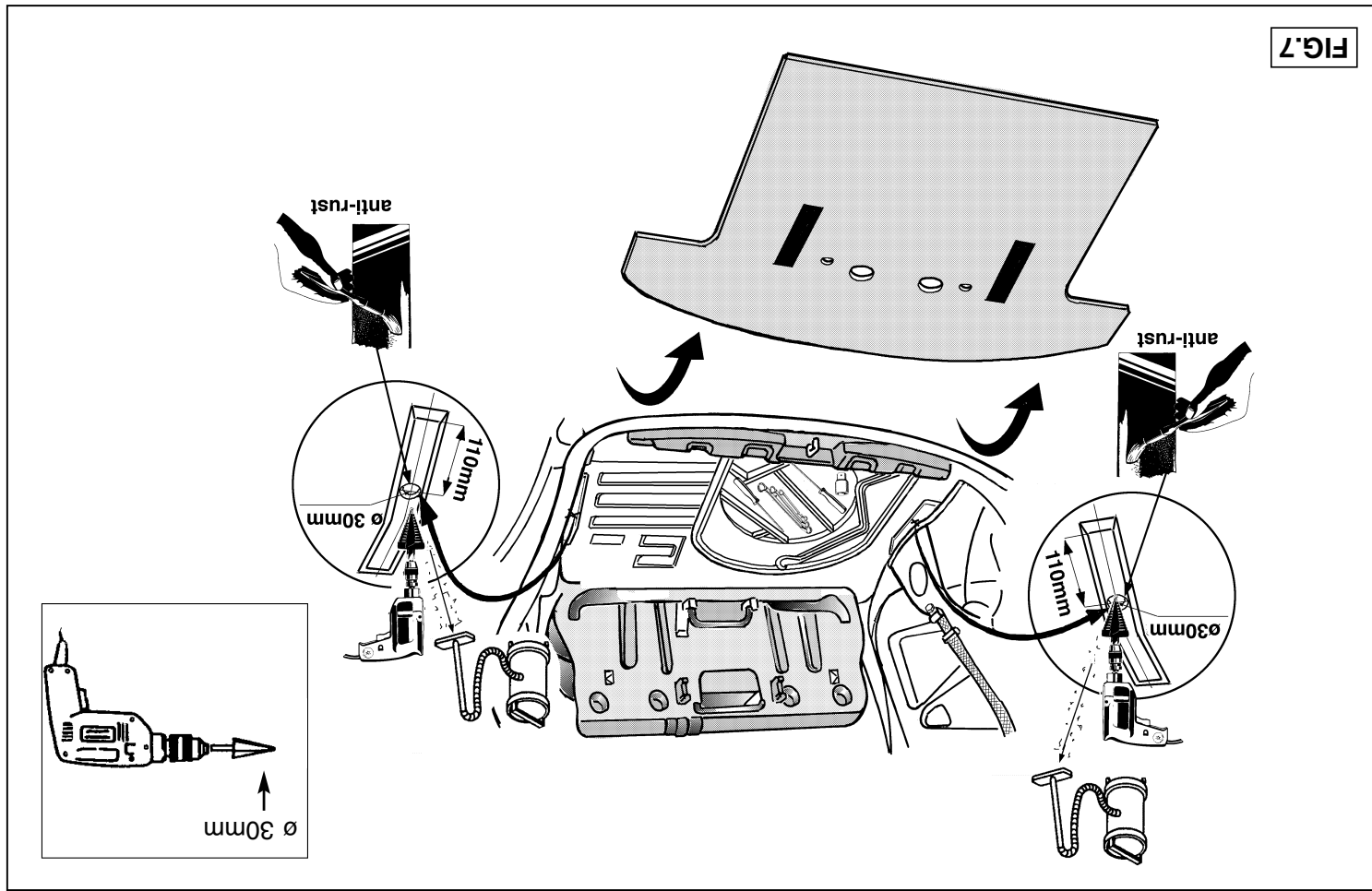

FIG.10A

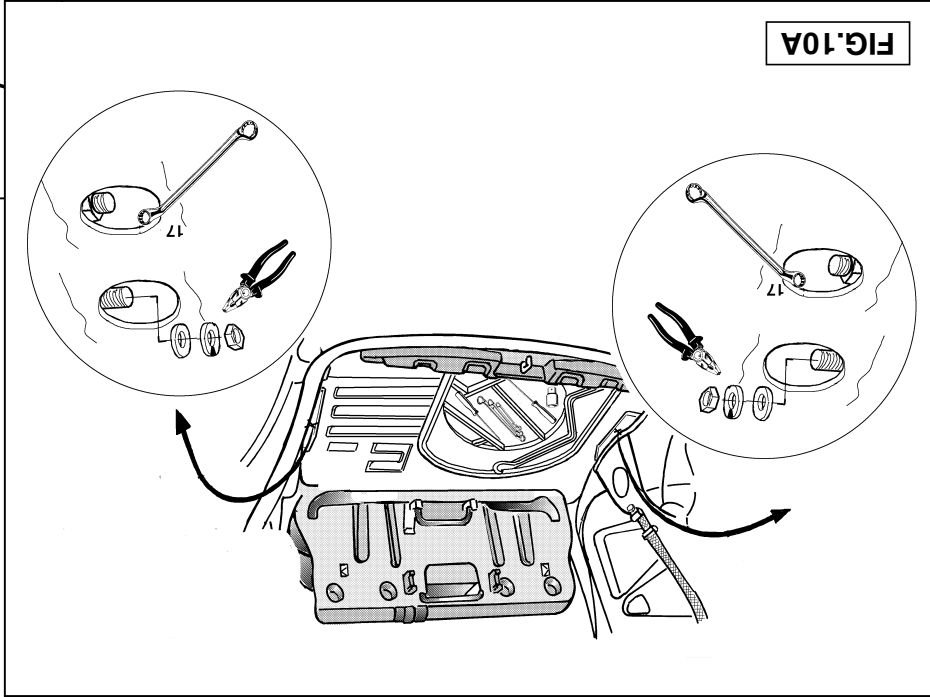
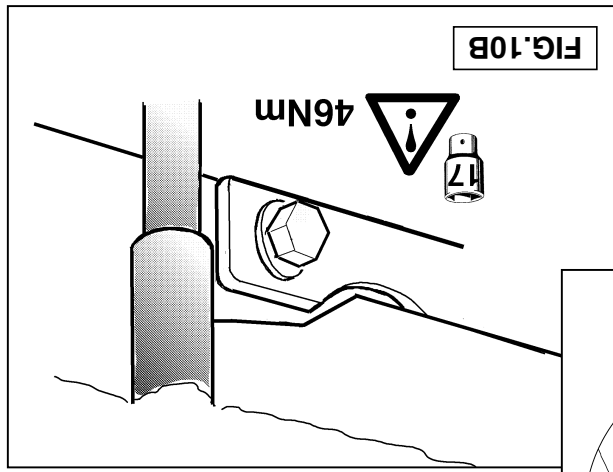
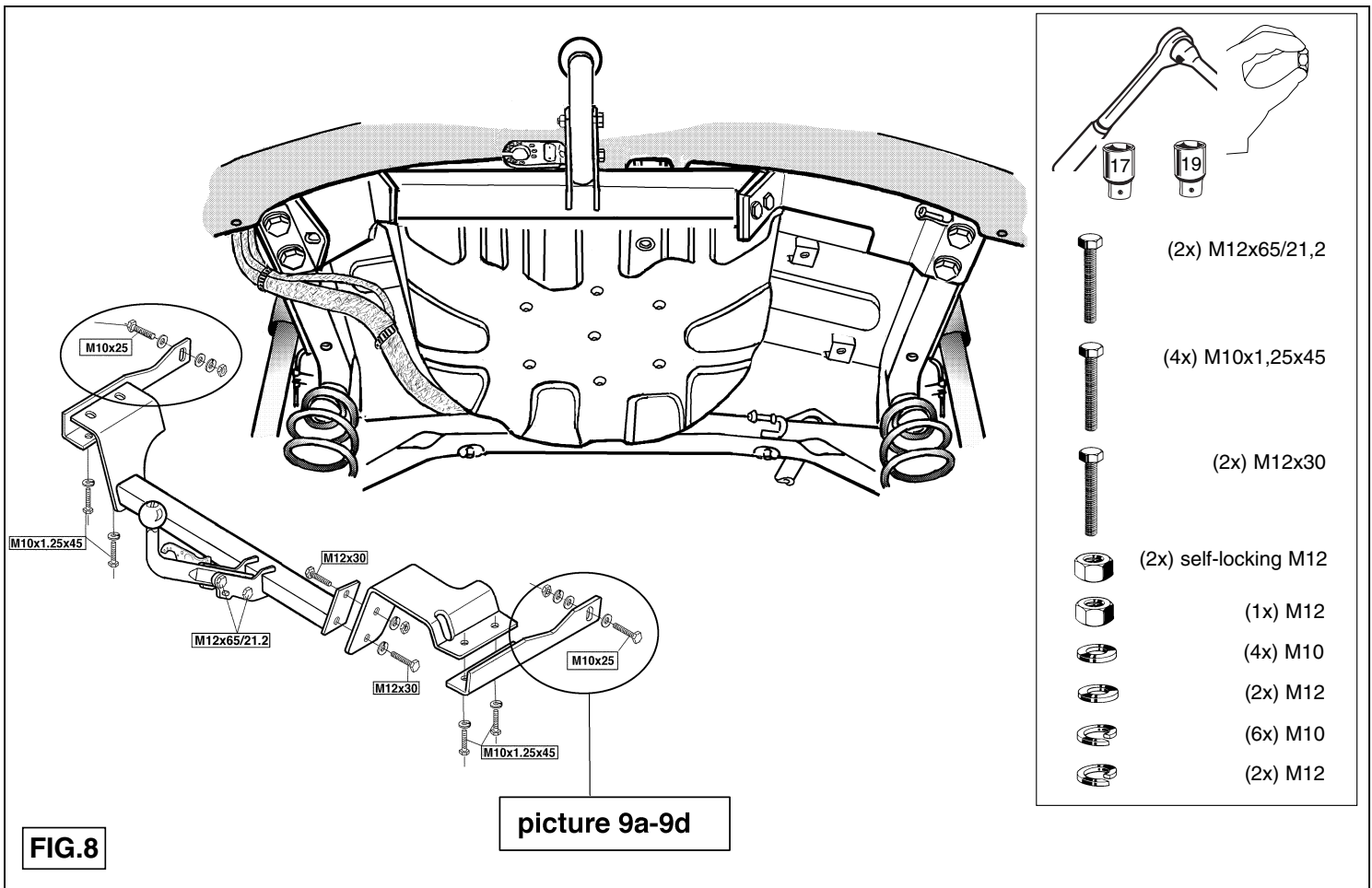
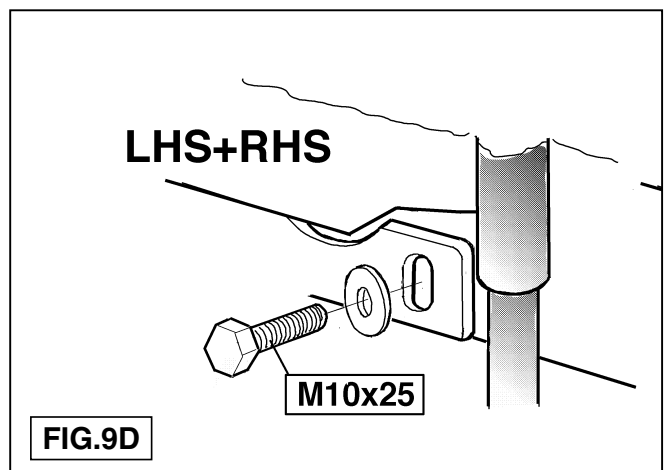
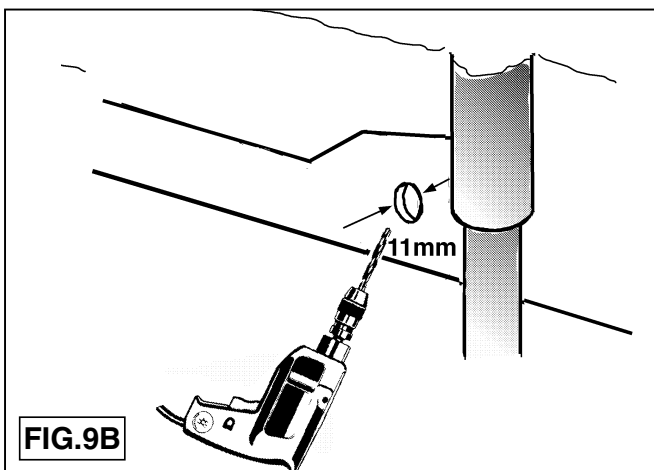
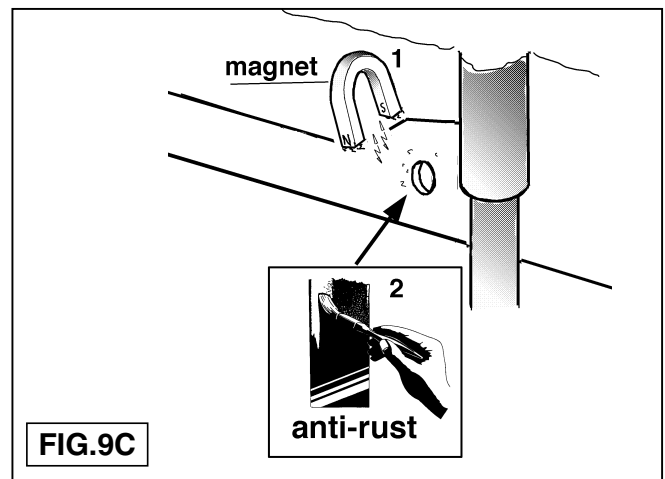
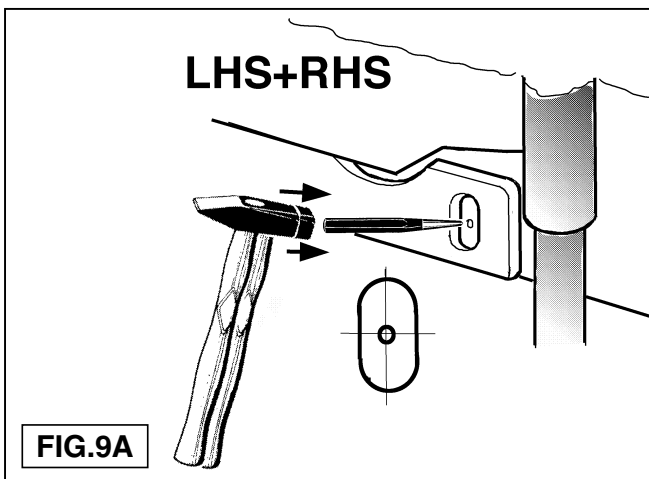

FIG.10B





© 388970/26-09-2003/9



© 388970/26-09-2003/10