



**DODGE**  
**RAM1500 DT**

2018 -

Cat. No. AM/107

**E20**

E20\*55R01/07\*005669\*00

**V = 12,00kN**



**D = 22,50kN**

D (kN) =



MAX kg

x

MAX kg

x 0,00981



MAX kg

+

MAX kg



**IMIOLA HAK-POL**

**96-111 KOWIESY, CHOJNATA 23A, POLAND**

**Tel. + 48 46 831 73 31, fax +48 831 74 29**

**e-mail: office@imiola.pl, www.imiola.pl**

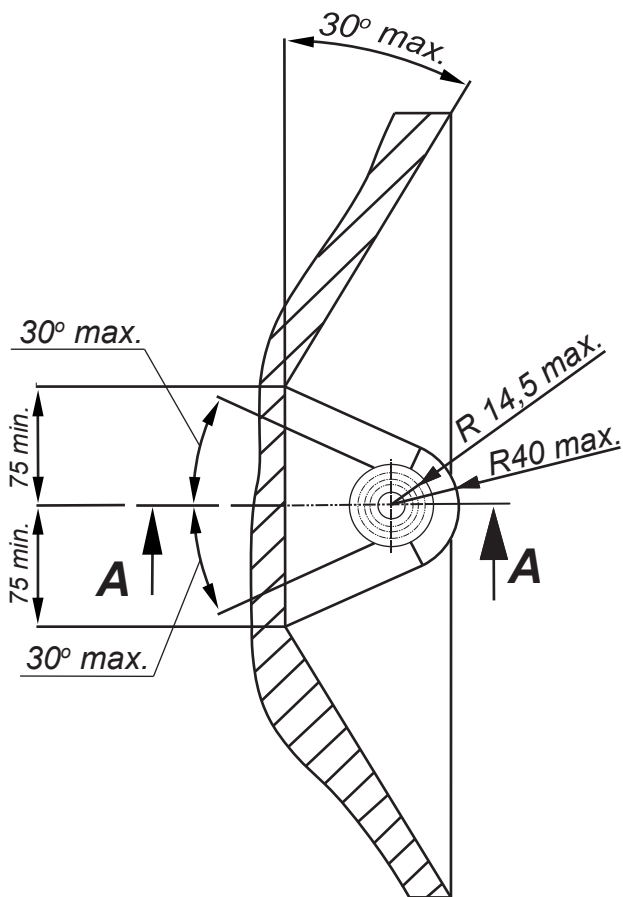

## PRZEKRÓJ A-A

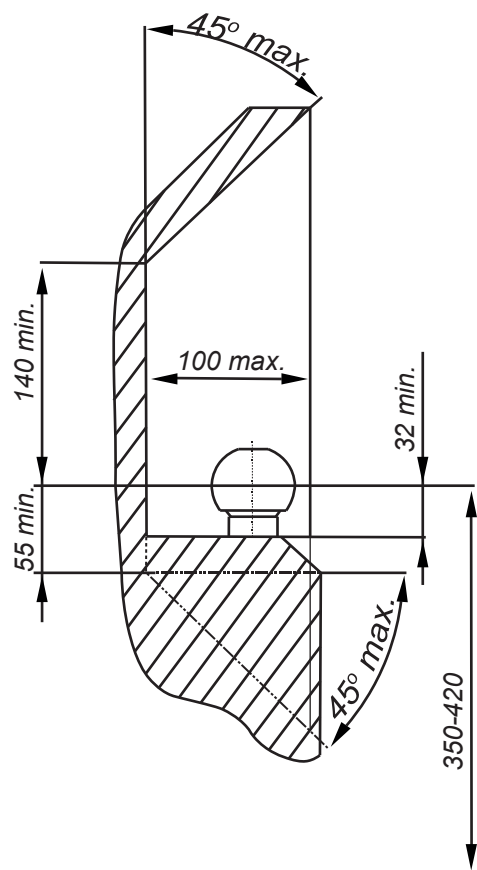

**PL** Należy zagwarantować przestrzeń swobodną według załącznika VII, rysunek 25a/b Regulaminu EKG ONZ 55.01 przy dopuszczalnym ciężarze całkowitym pojazdu.

**F** L'espace libre doit être garanti conformément à l'annexe VII, illustration de la réglementation 55.01 CE pour un poids total en charge autorisé du véhicule.

**GB** The clearance specified in appendix VII, diagram 25a/b of Regulation No. 55.01 UN EU must be guaranteed at laden weight of the vehicle.

**D** Der Freiraum nach Anhang VII, Abbildung 25a/b der Vorschriften 55.01 EG ist zu gewährleisten bei zulässigem Gesamtgewicht des Fahrzeuges.

Moment skręcający dla śrub i nakrętek (8.8) Torque settings for nuts and bolts (8.8)	
M8	25Nm
M10	55Nm
M12	85Nm
M14	135Nm
M16	195Nm

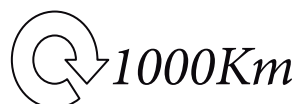

Śruba M12x40-8.8 ; Bolt  
Podkl. okr. Ø36x Ø13x 3 ; Plain Washer

Śruba M10x40-10.9 ; Bolt  
Podkl. okr. 10,5 ; Plain Washer

Śruba M12x35-8.8 ; Bolt

Nakrętka M16 ; Nut  
Podkl. spręż. 16,3 ; Spring Washer  
Podkl. okr. 17 ; Plain Washer

Nakrętka M12 ; Nut ; Bolt  
Podkl. spręż. 12,2 ; Spring Washer  
Podkl. okr. 13 ; Plain Washer

Nakrętka M10 ; Nut  
Podkl. spręż. 10,2 ; Spring Washer  
Podkl. okr. 10,5 ; Plain Washer  
Podkl. okr. 10,5 ; Plain Washer  
Śruba M10x35-8.8 ; Bolt

Śruba M14x1,5x40-8.8 ; Bolt  
Podkl. spręż. 14,2 ;  
Spring Washer  
Podkl. okr. Ø42x Ø15x 4 ;  
Plain Washer

Nakrętka M12 ; Nut  
Podkl. spręż. 12,2 ; Spring Washer  
Podkl. okr. Ø36x Ø13x 3 ; Plain Washer

Nakrętka M10 ; Nut  
Podkl. spręż. 10,2 ; Spring Washer  
Podkl. okr. 10,5 ; Plain Washer

Śruba M10x35-8.8 ; Bolt

Nakrętka M10 ; Nut  
Podkl. spręż. 10,2 ; Spring Washer  
Podkl. okr. 10,5 ; Plain Washer

Śruba z nadwozia samochodu ;  
The bolt from the body of the car

Śruba M16x110-8.8 ; Bolt







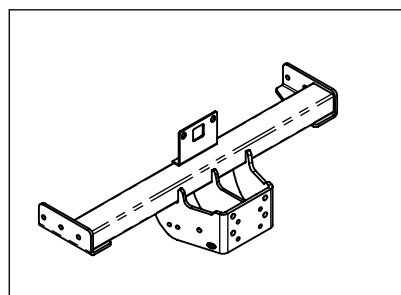
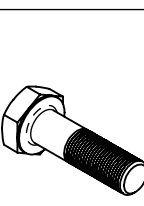
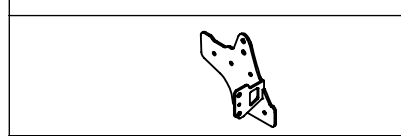
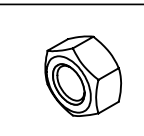

Śruba M12x35-8.8 ; Bolt

Śruba M14x50-8.8 ; Bolt

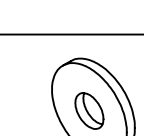
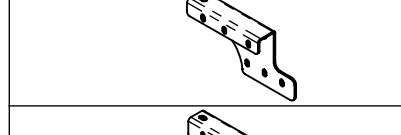
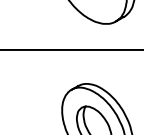
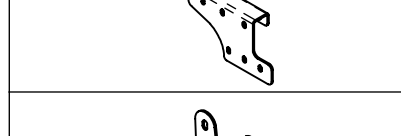
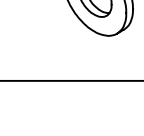
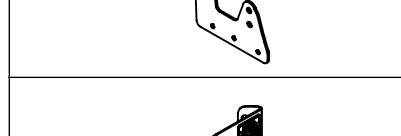
Nakrętka M12 ; Nut ; Bolt  
Podkl. spręż. 12,2 ; Spring Washer  
Podkl. okr. 13 ; Plain Washer

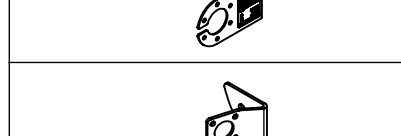
Śruba M14x1,5x40-8.8 ; Bolt  
Podkl. spręż. 14,2 ; Spring Washer  
Podkl. okr. Ø42x Ø15x 4 ; Plain Washer

Nakrętka M14 ; Nut ; Bolt  
Podkl. spręż. 14,2 ; Spring Washer  
Podkl. okr. 15 ; Plain Washer

	A	x1		M16x110	4
	C	x1		M14x1,5x40	4
	D	x1		M14x50	6
	E	x1		M12x40	2
	F	x1		M12x35	12
	G	x2		M10x40-10.9	4
	H	x1		M10x35	3
	I	x1		M16	4
				M14	4
				M12	14
				M10	7
				Ø42xØ15x4	4
				Ø36xØ13x3	4
				17	4
				15	10
				13	12
				10,5	12
				16,3	4
				14,2	10
				12,2	14
				10,2	7

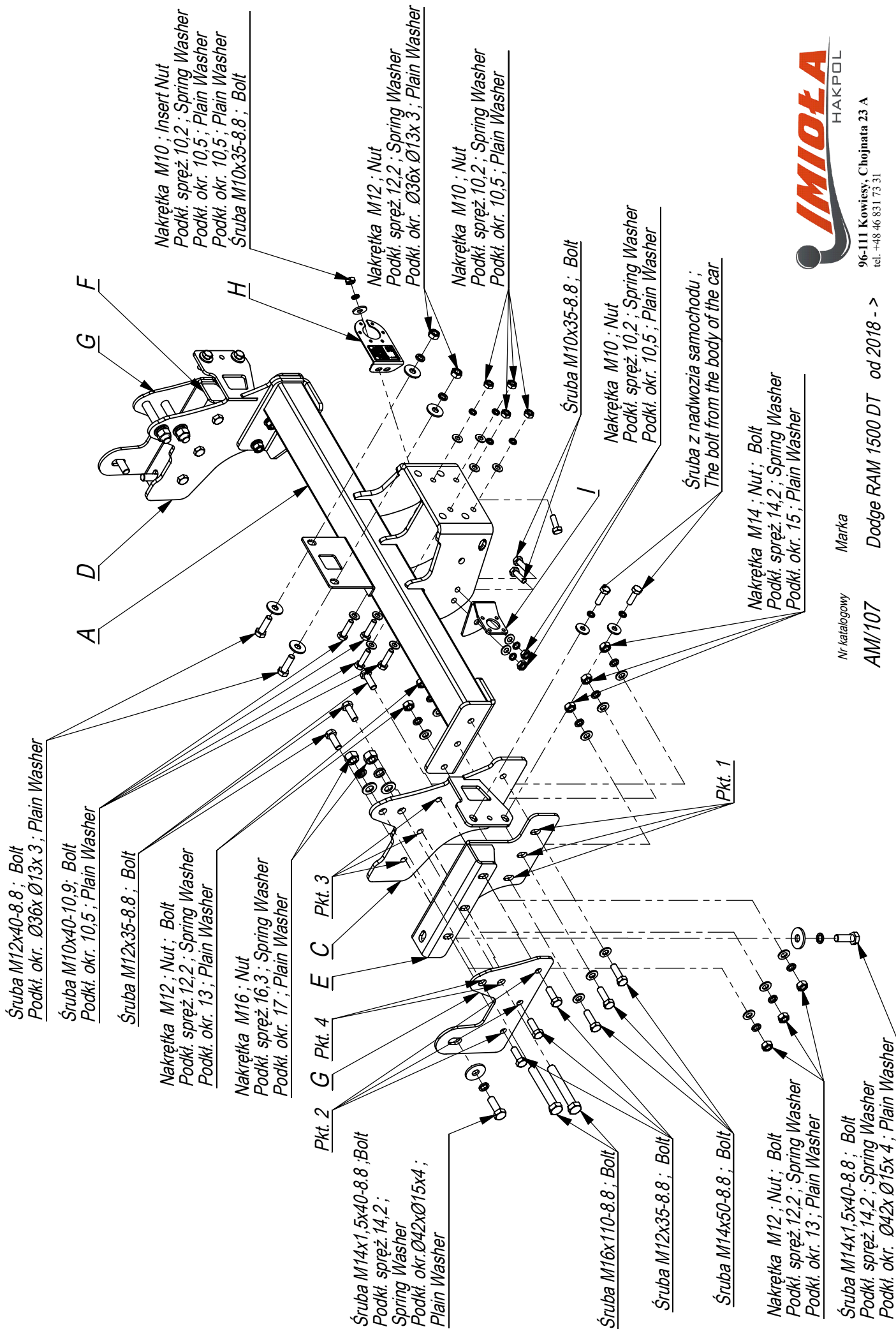

96-111 Kowiesy, Chojnata 23 A  
tel. +48-46 831 73 31

Nr katalogowy AM/107  
Marka Dodge RAM 1500 DT od 2018 ->

